

# MAINTENANCE MANUAL

## PUMPS

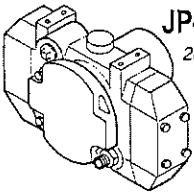

JP-402  
2857

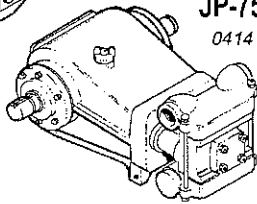

JP-75  
0414

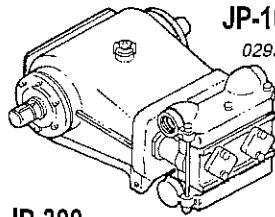

JP-100  
0293

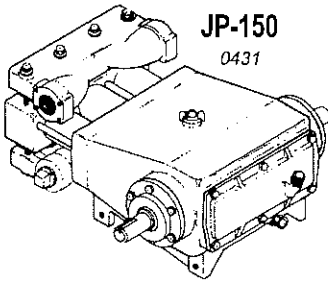

JP-150  
0431

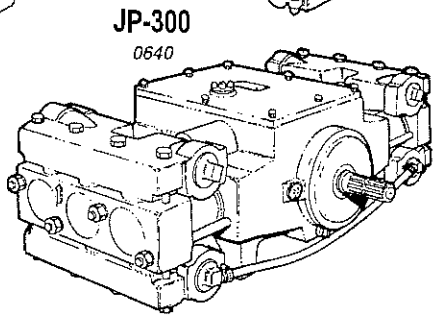

JP-300  
0640





## TABLE OF CONTENTS

Presentation	
Introduction .....	04
Identification plate .....	04
Specifications .....	05
Maintenance tools .....	05
Maintenance of JP-402 pump	
Disassembling the pump	
I - Disassembling the hydraulic part .....	07
II - Disassembling the mechanical part .....	08
Assembling the pump	
III - Crankshaft .....	10
IV - Crankshaft and pump body .....	12
V - Piston .....	13
VI - Valves .....	14
VII - Valve Analysis .....	15
VIII - Head .....	16
K - Lubrication .....	16
X - Final tests .....	17
Maintenance of JP-75 / 100 / 150 / 300 pumps	
Trouble-shooting	
1 - Excessive liquid leakage through the drain hole .....	19
2 - Liquid leakage between the cylinder and head .....	19
3 - Lubricating oil leakage through the drain hole .....	20
4 - Deficient suction and pumping .....	20
5 - Inner noises .....	21
6 - Preventive maintenance .....	21
Disassembling the pump	
1 - Disassembling the hydraulic part .....	22
2 - Disassembling the mechanical part .....	24
Checking the parts condition	
1 - Piston cup .....	26
2 - Tappet/Connecting rod .....	26
3 - Rod guide housing .....	27
4 - Crankshaft .....	27
5 - Valves .....	27
6 - Valve spring test .....	28
7 - Valve seal test .....	28
Assembling the pump	
1 - Bearing and crankshaft .....	29
2 - Connecting rod and rod guide .....	30
3 - Crankshaft .....	31
4 - Flanges .....	32
5 - Cylinder guide and ceramic cylinder .....	33
6 - Valves .....	34
7 - Head and valves cover .....	34
8 - Plugs .....	35
9 - Assembling and filling .....	36
10 - Lubrication .....	37
Statement of limited warranty .....	38

## INTRODUCTION

### INTRODUCTION

If used under good conditions, that is, with clean and sand-free water, properly diluted agrochemicals and daily cleaning, Jacto pumps are able to work for more than 500 hours with no need for repairs.

On the other hand, when using water containing sand and ill-diluted wettable powders, the pistons suffer early wear due to use and thus cause liquid leakages through the drain hole. Operating the pump of your sprayer for prolonged time with leakages will contaminate the grease (JP-402) and the lubricating oil (other pumps) and incorrect lubrication will cause damage to the connecting rods and bearings, thus raising the maintenance cost.

### IDENTIFICATION PLATE

In requesting replacement parts or maintenance, always specify the model and serial number of your pump for prompt and efficient service. These data are shown on the identification plate affixed to your pump.

	<b>jacto</b>	SPRAYER NUMBER
MODEL: _____		
MAX. PRESSURE		kgf/cm <sup>2</sup>
ROTATION:	rpm	POWER.: HP
FLOW RATE:		liters/min
MÁQUINAS AGRÍCOLAS JACTO S.A. - CGC 55.064.562/0001-90 POMPEIA - S.P. - MADE IN BRAZIL		

**Jacto** is trademark registered by Máquinas Agrícolas Jacto S.A.

## SPECIFICATIONS

### SPECIFICATIONS

FEATURES	PUMP MODEL				
	JP-402	JP-75	JP-100	JP-150	JP-300
Max. rotation on crankshaft	540rpm	540rpm	540rpm	540rpm	540rpm
Maximum working pressure	300psi	500psi	500psi	500psi	500psi
Flow rate (liters/min at 540 rpm)	40	75	100	150	300
Power required at 400 psi	2.2HP	5.3HP	7.0HP	10.7HP	24.0HP
Weight	19.5kg	37kg	47kg	60kg	125kg

### MAINTENANCE TOOLS

DESCRIPTION	PUMP MODEL				
	JP-402	JP-75	JP-100	JP-150	JP-300
L 1/2" spanner		X	X		
L 9/16" spanner	X			X	X
L 3/4" spanner		X	X	X	X
7/16" multiended wrench	X				
1/2" multiended wrench		X	X	X	X
3/4" multiended wrench		X	X		
3/4" open-ended spanner		X	X		
15/16" multiended wrench				X	X
15/16" open-ended spanner				X	X
Pliers for inner plastic ring	X	X	X	X	X
Plastic mallet	X	X	X	X	X
Torque wrench	X	X	X	X	X
1/2" socke wrench		X	X	X	X
9/16" socket wrench	X			X	X
3/4" socket wrench		X	X	X	X
15/16" socket wrench				X	X

# JP-402 PUMP MAINTENANCE

---

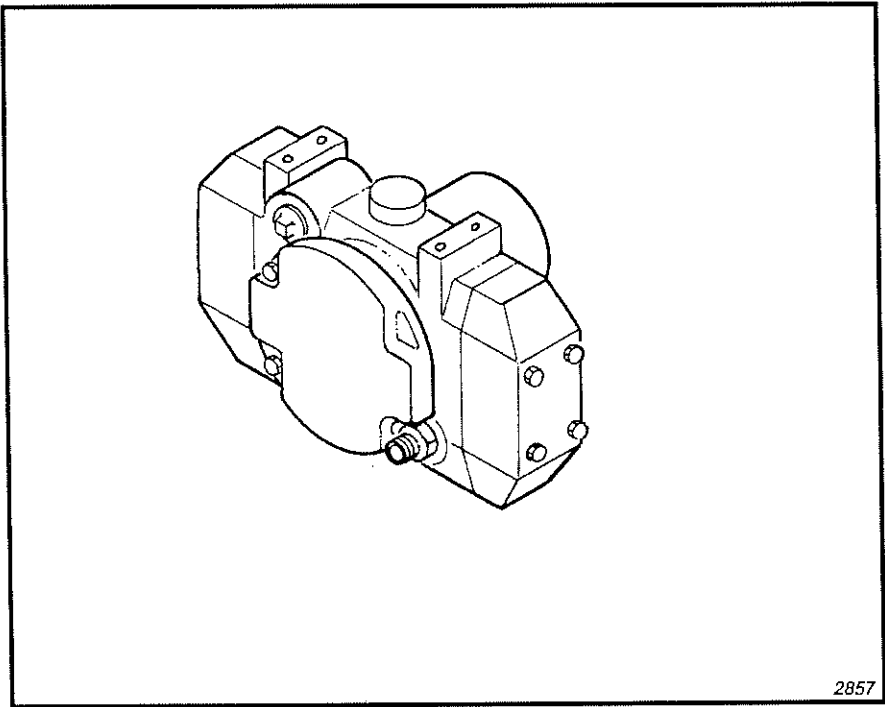

## DISASSEMBLING THE PUMP

### I - Disassembling the hydraulic part (heads)

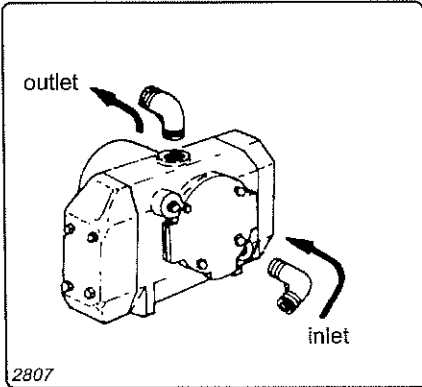

1 - Identify and mark the liquid inlet and outlet of the pump.

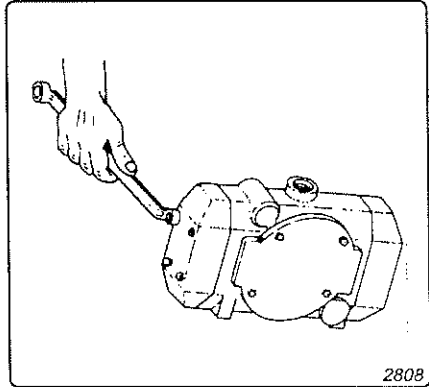

2 - Remove the heads and observe how the inlet and outlet valves are mounted, in order to not mount it invert.

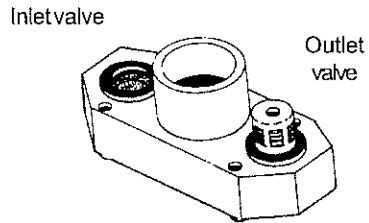
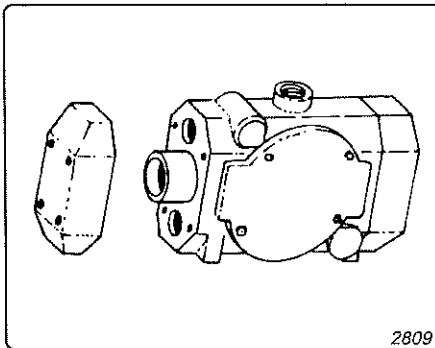

## DISASSEMBLING THE PUMP

3 - Remove the bolt that is fixing the piston and take out the whole assembly.

- bolt,
- piston,
- piston cup,
- sleeve,
- connecting rod guide, etc.

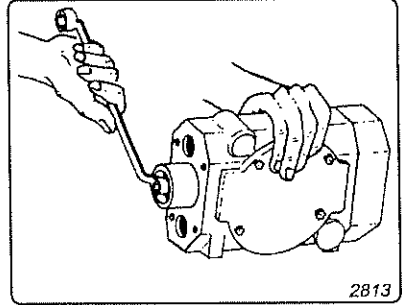

4 - Repeat this operation on the other head.

## II - DISASSEMBLING THE MECHANICAL PART

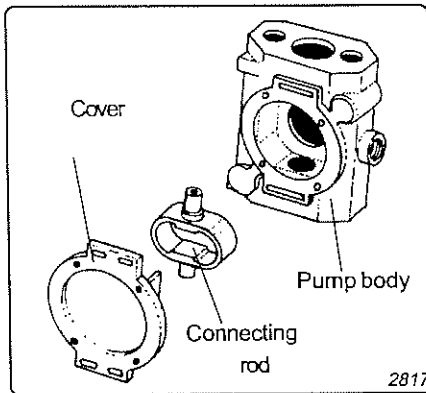

1 - Remove the cover and the connecting rod.

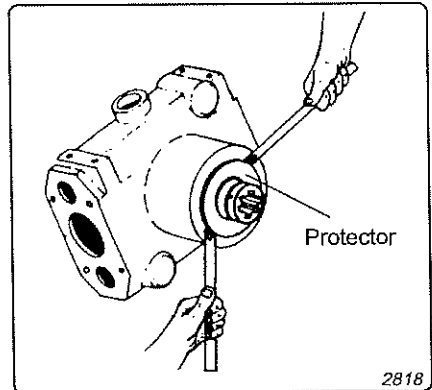

2 - Remove the dust guard and the seal with a spatula.



## DISASSEMBLING THE PUMP

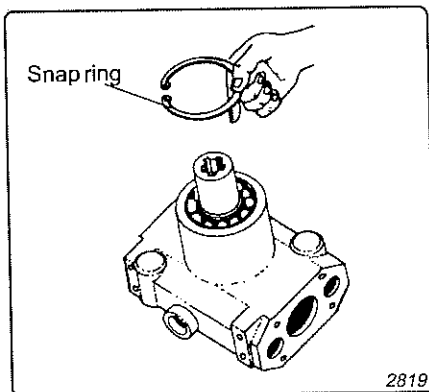

3 - Remove the snap ring that is placed in the pump body.

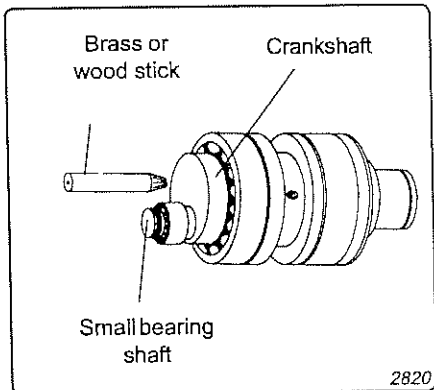

4 - Tap the crankshaft with a brass stick to remove it from the pump body.

**Attention:** Never tap the small bearing shaft to avoid damaged.

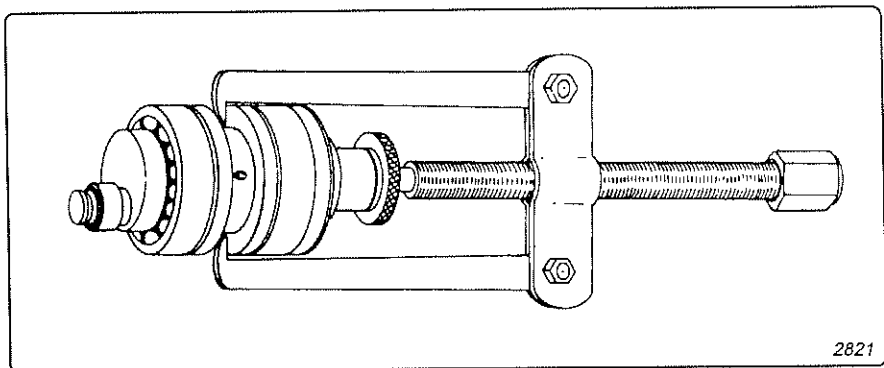

5 - Remove the crankshaft bearings with an extractor, or use a press properly supported.

## ASSEMBLING THE PUMP

### III - Crankshaft

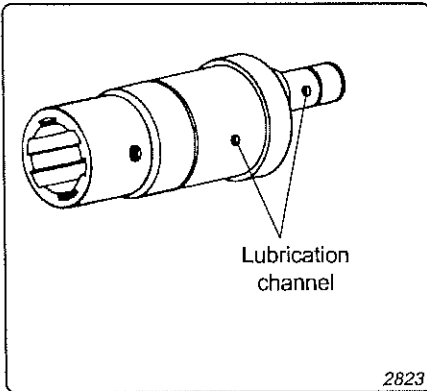
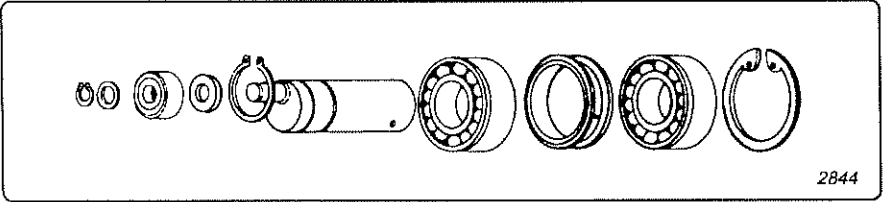

1 - Check if the lubrication channels are obstructed.

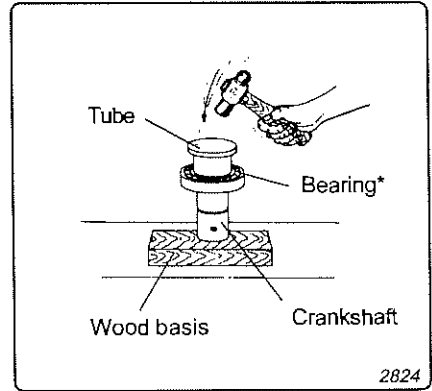

2 - Mount the bearing (with the grease deflector toward the outside). Tap until it rests.

\*The bearing is armor-plated on one side, which must be toward the outside so that the other receives the lubrication.

NOTE: THE TUBE USED TO MOUNT THE BEARING SHOULD TOUCH ONLY THE BEARING INNER TRACK.

## ASSEMBLING THE PUMP

NOTE: The armor-plated side must face the outside.

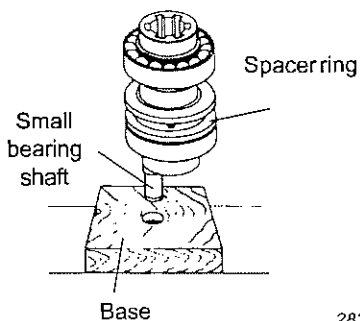

3 - Install the spacer ring and the other bearing with the grease deflector facing the outside.

Small bearing shaft housing

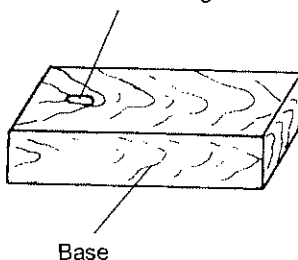

NOTE: To support the crankshaft use a piece of wood with a hole, in which to fit the small bearing shaft.



4 - Needle bearing.



- Mount the bearing and lock it.

## ASSEMBLING THE PUMP

### IV - Mounting the crankshaft assembly to the pump body

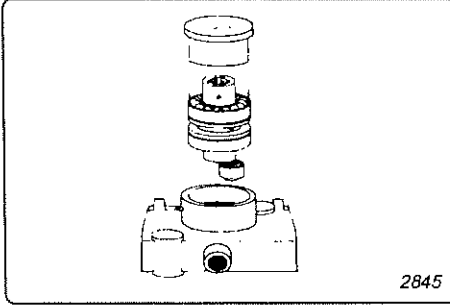

1 - Align the crankshaft assembly to the pump body and tap the external cap (use a tube) until housing completely the assembly.

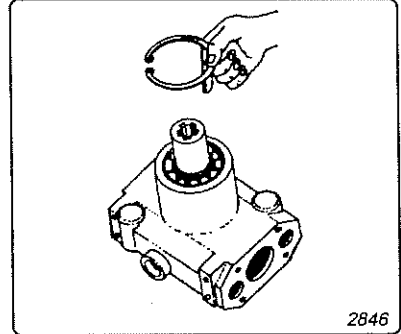

2 - Lock the entire assembly by installing the snap ring.

3 - Place the seal and the dust guard.

NOTE: Place the seal with the edge upward, so the seal can eliminate the grease excess and prevent dirt from entering.

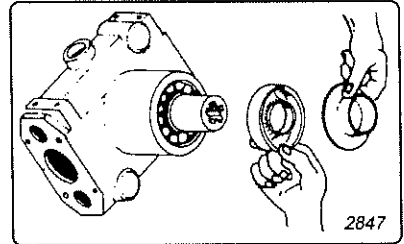

4 - Install the matching cover and the external cover.

-Fit the screws and tighten them sequenced crosswise with 0.5 kgf/m torque.

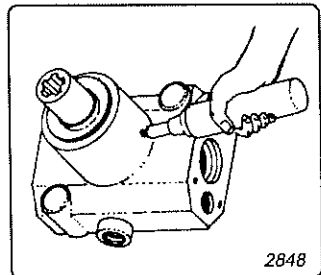
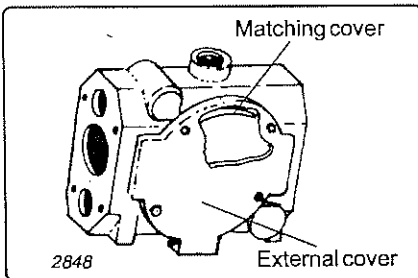

5 - Lubricate the pump with grease.

## ASSEMBLING THE PUMP

### V - Mounting the pistons assembly

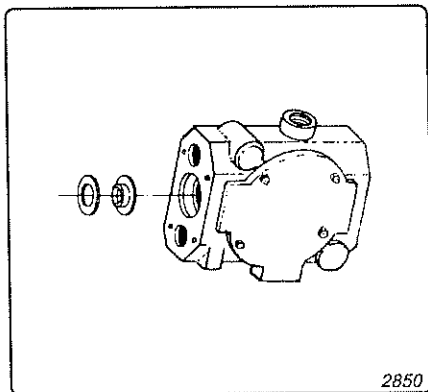

1 - Install the seal and the seat washer.

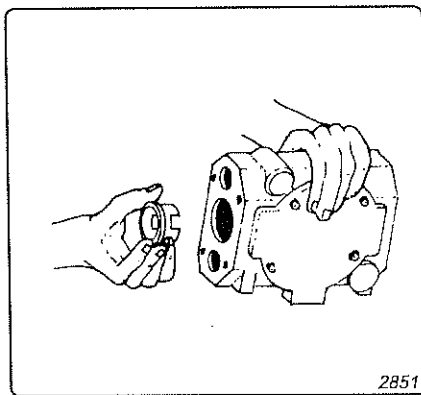

2 - Fit the spacer bushing and the o-ring over the spacer bushing.

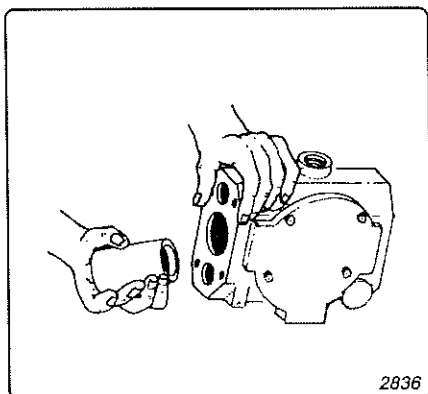

3 - Mount the ceramic sleeve and the o-ring around the sleeve.

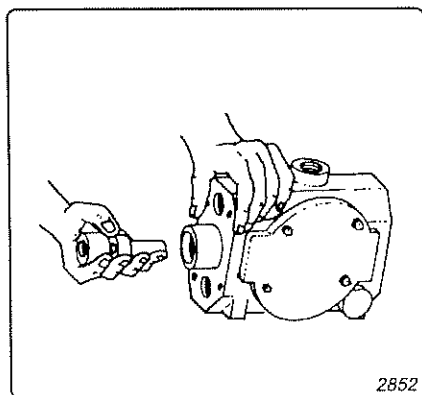

4 - Install the tappet on the connecting rod with the piston cup guide.

## ASSEMBLING THE PUMP

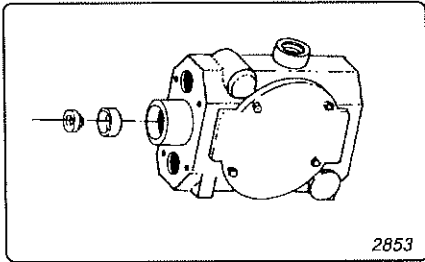

5 - Install the piston cup with the piston.

7 - Tighten it with 3.5 kgf/m torque.

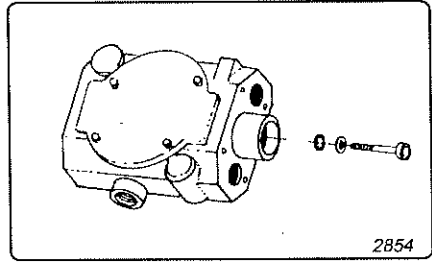

6 - Fit the fixing bolt with the o-ring and the flat washer.

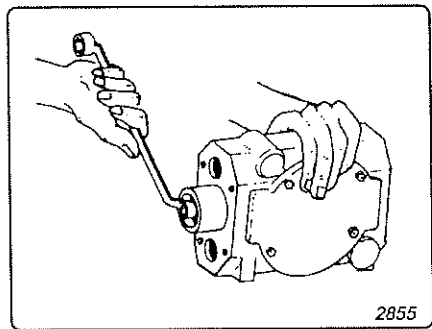

8 - Do the same with the other piston assembly.

### VI- VALVES

- Fit the spring and the disc into the cage.
- Position the seat and the guide ring.
- Install the valve seal.

**ATTENTION:**

Make sure the parts are clean, free from impurities and mainly from abrasive chemicals

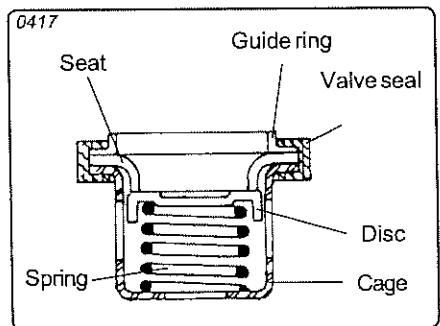

## ASSEMBLING THE PUMP

### VII-VALVE ANALYSIS

#### 1- Valve spring

-Fit the spring, packing disc and seat in the cage.

-Place weights of 100 g (for JP-75 & JP-100 pumps) and 200 g (for JP-150 & JP-300 pumps) on the seat and check if the seat rests on the cage. If not, replace the spring and test again.

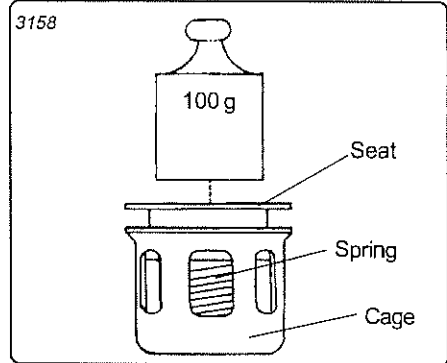

Valve with improper seal caused by wear, impurities or stuck disc results in deficient suction and pumping.

#### 2-Valve seal

- Place a thin sandpaper on a straightener and smooth the seating sides of the disc and valve seat with 8-shaped movements.

- Mount the valve and pour water as shown in the figure.

- If it leaks, replace the valve.

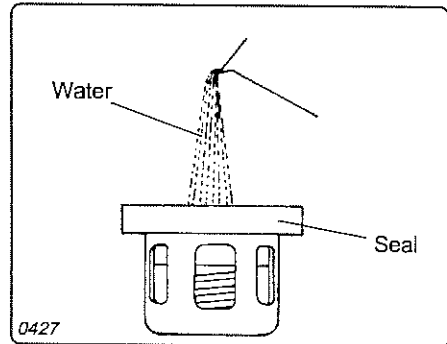

### ATTENTION

Replace the seals whenever disassembling the valve for repair.

## ASSEMBLING THE PUMP

### VIII - Assembling the head

- Mount the heads according to the identification (inlet and outlet) made on the beginning of the disassembling.

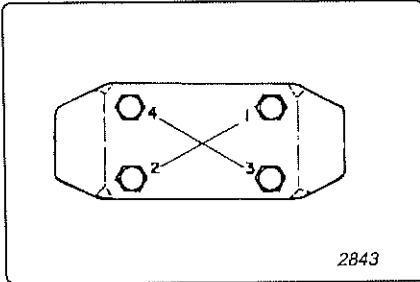

- Mount the bearing and lock it.

### TORQUES:

1st fase

1.4 to 2 kgf/m (10 to 15 lb/foot).

2nd fase

2.8 to 3.5 kgf/m (20 to 35 lb/foot).

3rd fase:

3.5 kgf/m (25 lb/foot).

### IX - Lubrication

-Lubricate the pump daily, using Lithium base NGLI-2 grease.

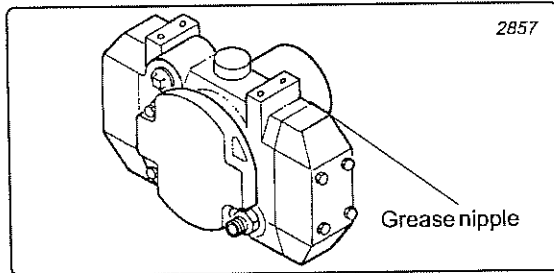



## **ASSEMBLING THE PUMP**

### **X - FINAL TESTS**

After finishing the pump assembly, do the following tests to check if the pump was correctly repaired.

1st test: Operate the pump for 10 minutes with no pressure in the circuit.

2nd test: LIQUID LEAKAGE THROUGH THE DRAIN HOLE.

Check if the leakage was eliminated by operating the pump with pressure in the circuit.

3rd test: WEAR OF MOVING PARTS

Check if the clearance on the bearings and the strong metallic noises were eliminated with the pump running at the working pressure.

4th test: SUCTION AND PUMPING DEFICIENCY

Determine the pump actual capacity.( REFER TO THE INFORMATION SHEET )

# JP-75 / 100 / 150 / 300 PUMPS MAINTENANCE

---

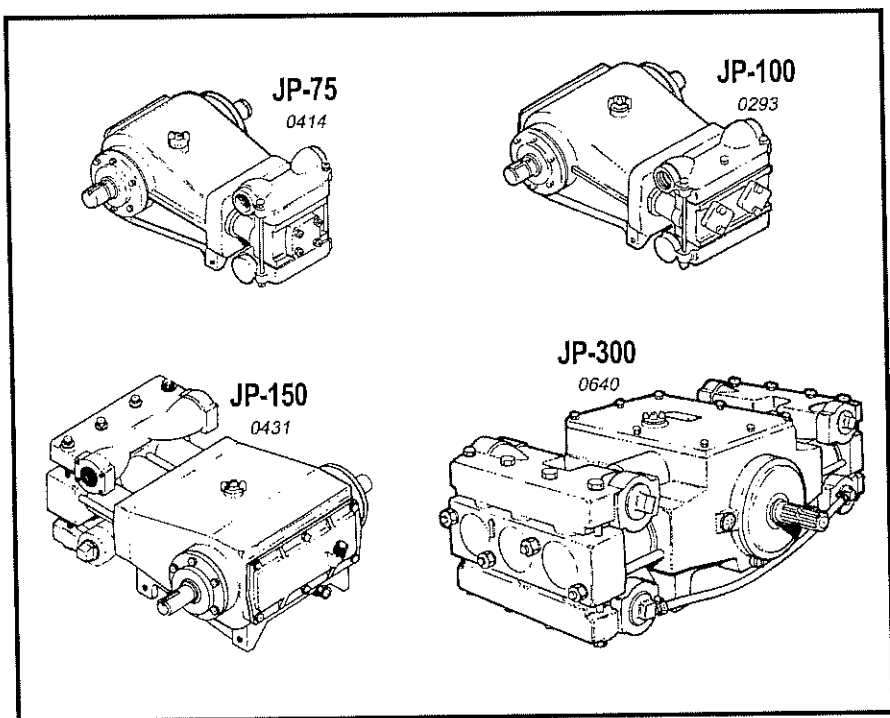

## TROUBLE-SHOOTING

### 1- Excessive liquid leakage through the drain hole.

There will be leakage if:

- the piston cup is damaged (fig. 0430 - part 8).
- the nut fixing the piston cup is not tightened. (fig. 0430 - part 12).
- the packing ring is damaged (fig. 0430 - part 10).

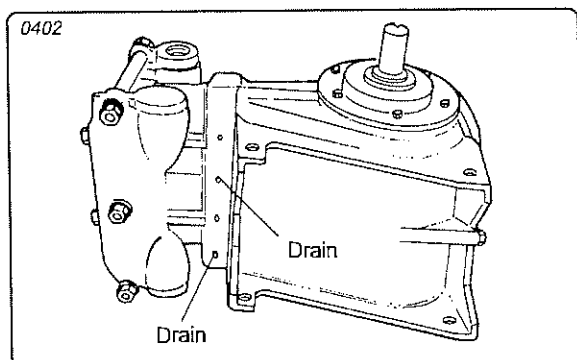

### 2- Liquid leakage between the sleeve and head.

- Retighten the head nuts (fig. 0429).
- If the leakage continues, replace the packing ring (fig. 0430 - part 6).

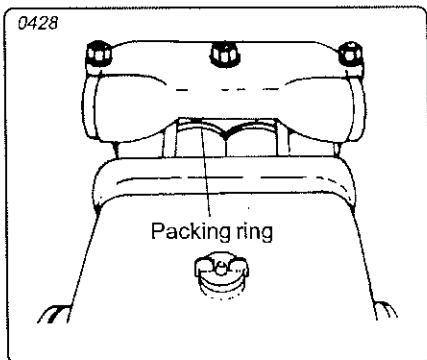
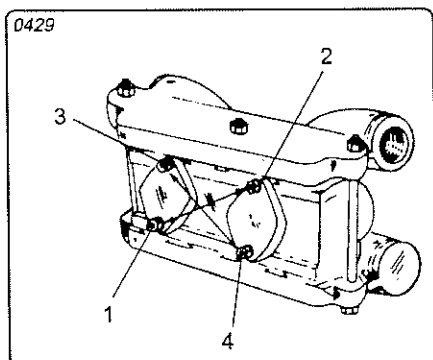

## TROUBLE-SHOOTING

### 3-Lubricating oil leakage through the drain hole

This can happen due to obstruction in the breather, deficient rod seal (part 02) and sleeve guide seal (part 3) or improper tightening of the nuts fixing the head.

- |                   |                      |
|-------------------|----------------------|
| 01 - Snap ring    | 07 - Piston cup seat |
| 02 - Seal         | 08 - Piston cup      |
| 03 - Packing      | 09 - Piston          |
| 04 - Sleeve guide | 10 - Packing ring    |
| 05 - Sleeve       | 11 - Flat washer     |
| 06 - Packing ring | 12 - Nut             |

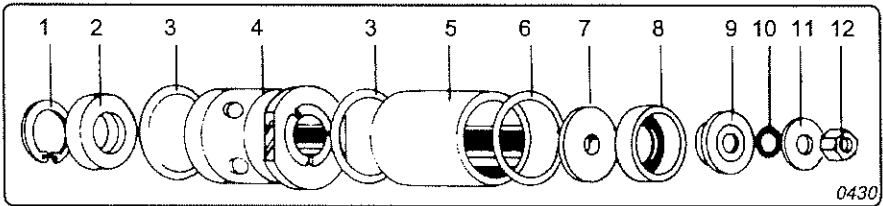

### 4-Deficient suction and pumping

It can be caused by:

- Damaged valve;
- deficient packing on the valves due to impurities or stuck disc;
- incorrect mounting of valves.

To confirm if this deficiency is really caused by the valves, measure the pump actual flow rate.

- Disconnect the return hose from the control valve and connect the filler unit hose.
- Run the sprayer with 540 rpm at PTO.
- Collect water for one minute.
- Measure the volume collected.

NOTE: The volume collected should approximate this shown below for each pump model:

- JP-402 = 40 liters/min
- JP-75 = 75 liters/min
- JP-100 = 100 liters/min
- JP-150 = 150 liters/min
- JP-300 = 300 liters/min

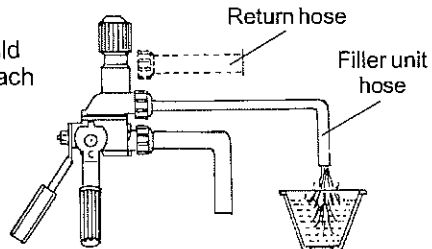

## TROUBLE-SHOOTING

### 5- Inner noises

These noises result from wear on the connecting rod bearing.

**ATTENTION:** Check for the exact location of the noises. There may also be noises if the filter is obstructed or a valve is not operating properly, thus leading you to a wrong diagnosis.

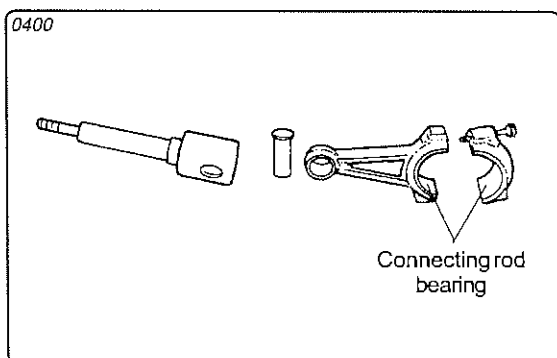

### 6- Preventive maintenance

Pumps have parts which usually operate under rigorous conditions and thus are subject to normal wear after a reasonable time of use. On our pumps the piston cup, which is in continuous contact with abrasive chemical mixtures, is subject to wear and therefore can cause liquid leakage through the drain hole. To avoid that such a simple problem damage other parts of the pump, a preventive maintenance at the end of the spraying season or every 300 hours is advisable, with the examination of the pistons set and replament of the damaged parts.

## DISASSEMBLING THE HYDRAULIC PART

**ATTENTION:** Observe the parts when disassembling the pump in order to identify those damaged.

### 1-Disassembling the hydraulic part

- Remove the stud bolts fixing the valves cover.
- Remove the valves cover.

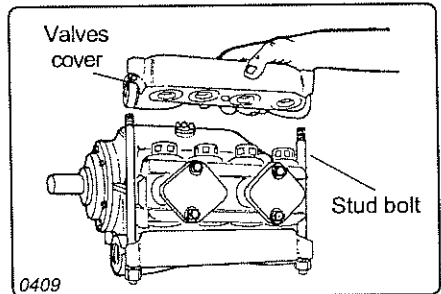

- 1.1- Remove the nuts fixing the head, clip plates and head.

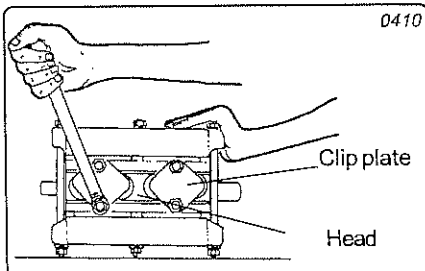

- 1.2- Remove the nut fixing the piston cup.

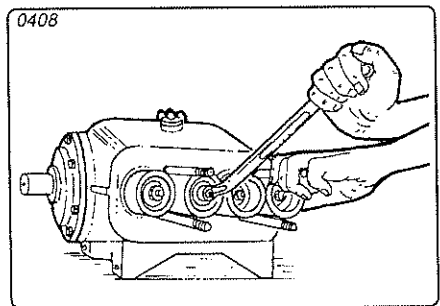

- 1.3- Remove the nut (12), brass washer (11), packing ring (10) and piston (9).

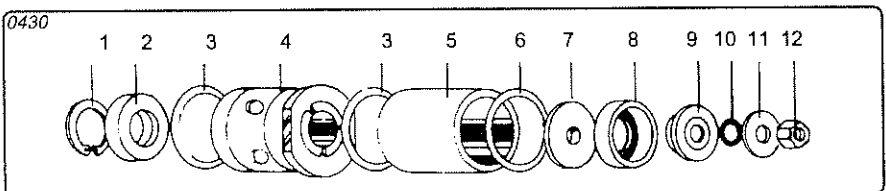

## DISASSEMBLING THE HYDRAULIC PART

- 1.4- Remove the sleeve with the piston cup and the base.  
- Repeat this operation with the other cylinders.

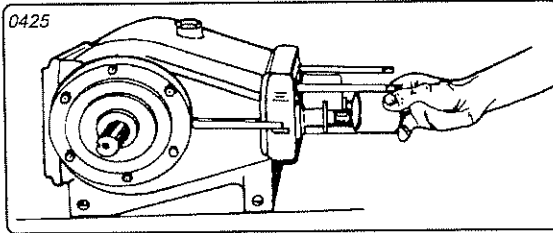

- 1.5- Remove the sleeve seal and the packing.

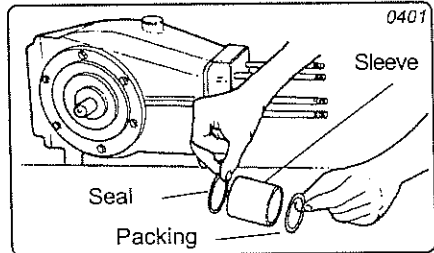

- 1.6- Drain the oil. Remove the sleeve guide.

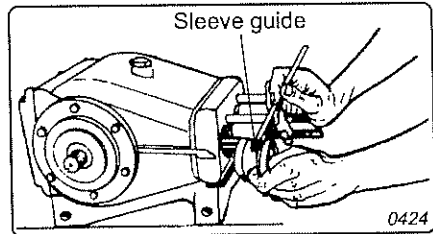

- 1.7- Remove the snap ring from the sleeve guide and the seal.

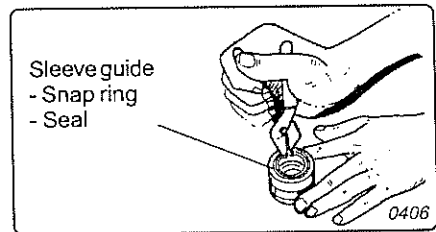

## DISASSEMBLING THE MECHANICAL PART

### 2-Disassembling the mechanical part

2.1- Remove the crankcase cover.

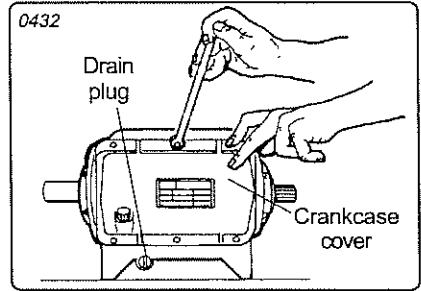

2.2- Remove the bolts that fix the connecting rods.

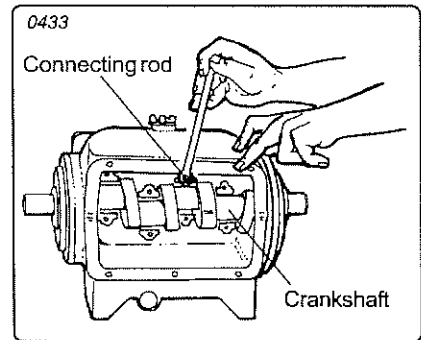

2.3- Remove the bolts and the flanges

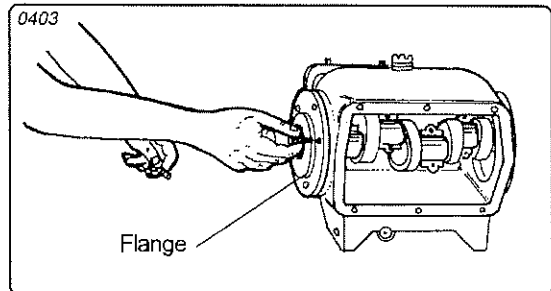



## DISASSEMBLING THE MECHANICAL PART

2.4- Pull out all the tappets to the front so as to free the crankshaft.

NOTE: Remove the crankshaft carefully in order to avoid impact on the connecting rod journal.

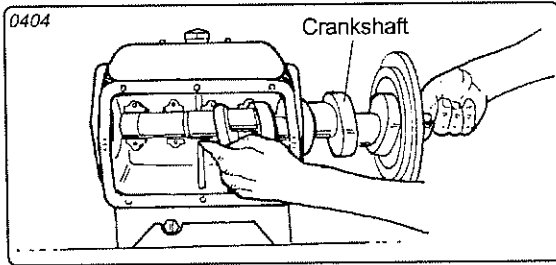

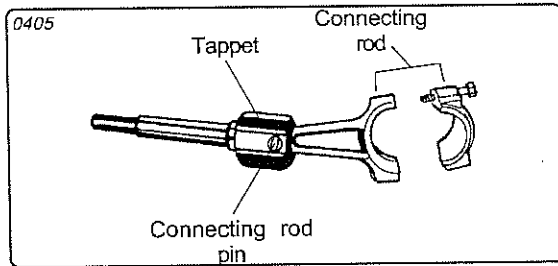

2.5 - Remove the tappets with the connecting rod and the connecting rod pin.



## CHECKING THE PARTS CONDITION

### 1-Piston cup

Condition	Causes
Thinner wall	Normal wear due to time of use.
Wear and scratch	a) Improper maintenance - the inside of the pump is not rinsed after the application of wettable powdered agrochemicals which are built up on the cylinder and head walls. b) Use of water containing sand - improper filtering during the filling operation. c) Chemical mixture leakage when using wettable powdered agrochemicals.
<div style="display: flex; justify-content: space-around; align-items: center;"> <div style="text-align: center;">  <p>Normal</p> <p>0434</p> </div> <div style="text-align: center;">  <p>Worn</p> <p>0435</p> </div> </div>	 <p>0435</p> <p>Worn or scratched piston cups cause liquid leakage through the drain hole.</p>

**ATTENTION:** Whenever disassembling the sleeve and piston cup assembly for repair, replace the following parts (see figure 0430): sleeve seal (3), packing ring (06) and packing ring (10).

### 2-Tappet - Connecting rod

- Check if the guides and rods are not worn or scratched.
- Check if the connecting rod pin is not worn.
- Check if the connecting rod eye is not worn.
- Check if the connecting rod bearing is not worn or scratched.

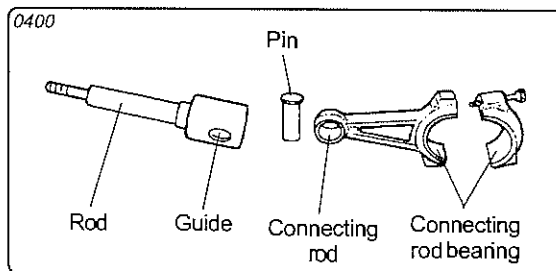

## CHECKING THE PARTS CONDITION

### 3-Rod guide housing

-Check if it is not slack or worn.

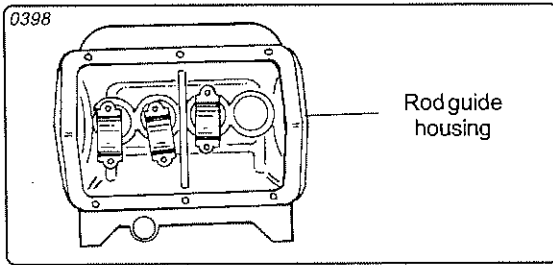

### 4- Crankshaft

- Check if the crankshaft journal is not scratched.

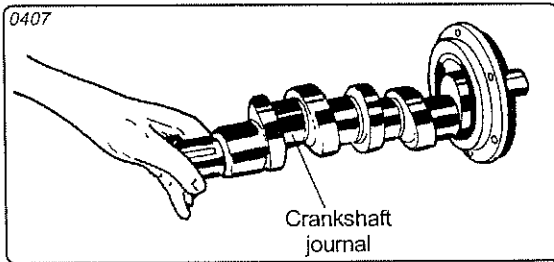

### 5-Valves

Check:

- 1-Cage
- 2- Spring
- 3- Packing disc
- 4- Seat
- 5- Seal
- 6- Valve guide

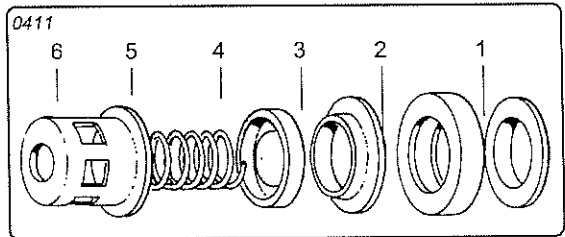

**ATTENTION:** Overcharge on the valve spring will result in deficient suction and pumping.

## CHECKING THE PARTS CONDITION

### 6- Valve spring

-Fit the spring, packing disc and seat in the cage.

-Place weights of 100 g (for JP-75 & JP-100 pumps) and 200 g (for JP-150 & JP-300 pumps) on the seat and check if the seat rests on the cage. If not, replace the spring and test again.

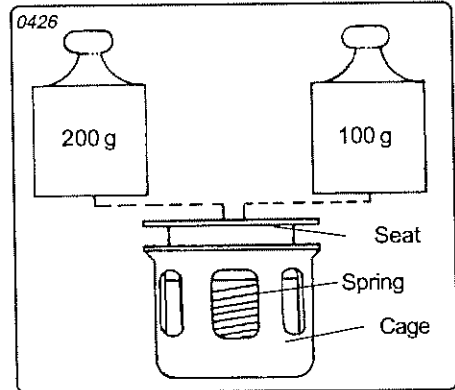

Valve with improper seal caused by wear, impurities or stuck disc results in deficient suction and pumping.

### 7-Valve seal

- Place a thin sandpaper on a straightener and smooth the seating sides of the disc and valve seat with 8-shaped movements.

- Mount the valve and pour water as shown in the figure.

- If it leaks, replace the valve.

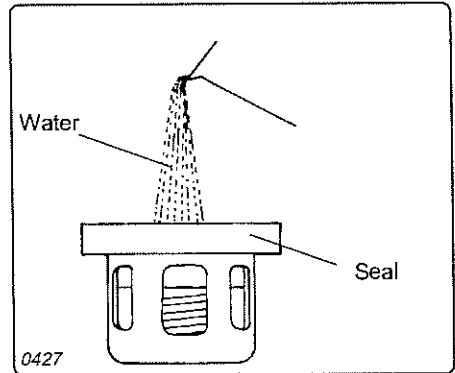

### ATTENTION

Replace the seals whenever disassembling the valve for repair.

## ASSEMBLING THE PUMP

Some specific tools are required for assembling the pump. In case you do not have them, try to use those available, provided that you do not damage the parts.

Follow strictly the sequence shown below.

### 1- Bearing and crankshaft assembly

NOTE: Make sure they are clean.

- Place the crankshaft on the aluminum plate.
- Install the bearing guide
- Position the bearing with the numbers upward.
- Press the bearing until it is set to the indicated position.
- Disassemble the extension and guide.

NOTE: To follow the same sequence for mounting the other bearing..

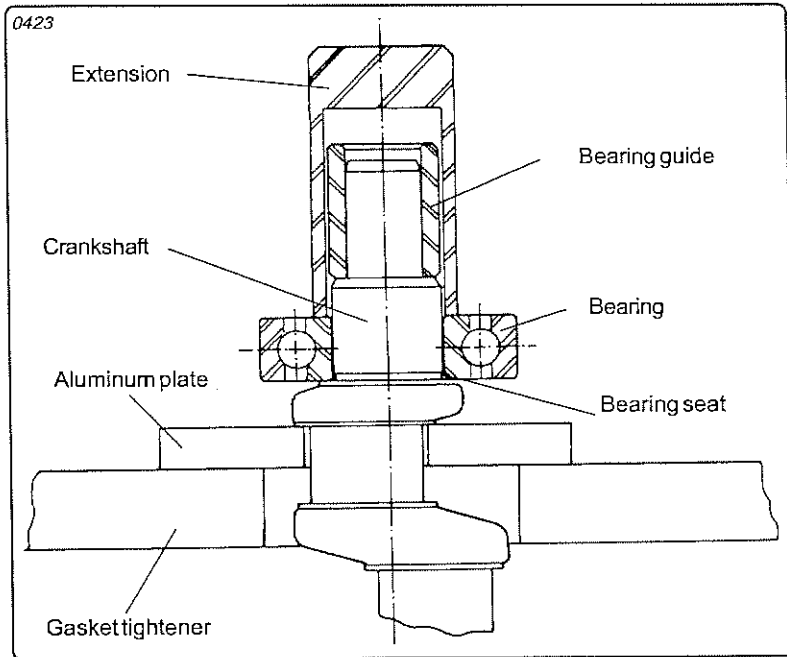

## ASSEMBLING THE PUMP

### 2- Connecting rod and rodded guide

NOTE: Make sure they are clean.

- Fit the connecting rod into the rodded guide.
- Lubricate with oil (API-SB or superior SAE-30) the connecting rod pin and mount the assembly.
- Lubricate with oil (API-SB or superior SAE-30) the rodded guide and the guide housing (on the pump body). Next mount this assembly to the pump body as shown in the figure below.

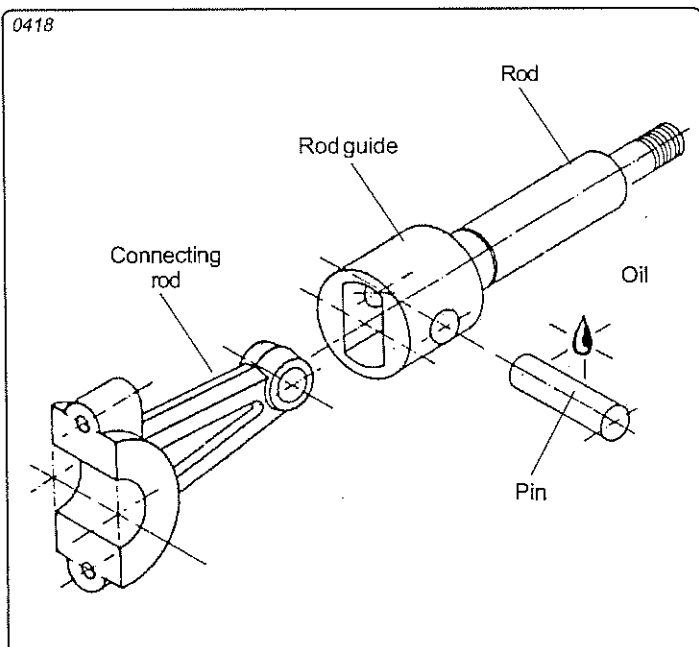

## ASSEMBLING THE PUMP

### 3-Crankshaft

- Lubricate with oil (API-SB or superior SAE-30) the bearings housing.
- Mount the crankshaft with the bearings to the pump body.
- Lubricate with oil (API-SB or superior SAE-30) the crankshaft journals.
- Mount the other part of the connecting rod and fit the screws (apply low torque chemical bond) by following the numerical sequence engraved on the connecting rod.
- Tighten the screws all the way: 1.9 kgf/m torque for the JP-75 & JP-100 pumps and 2.8 kgf/m torque for the JP-150 pump.

NOTE: Make sure the crankshaft can be turned with the hands after being tightened.

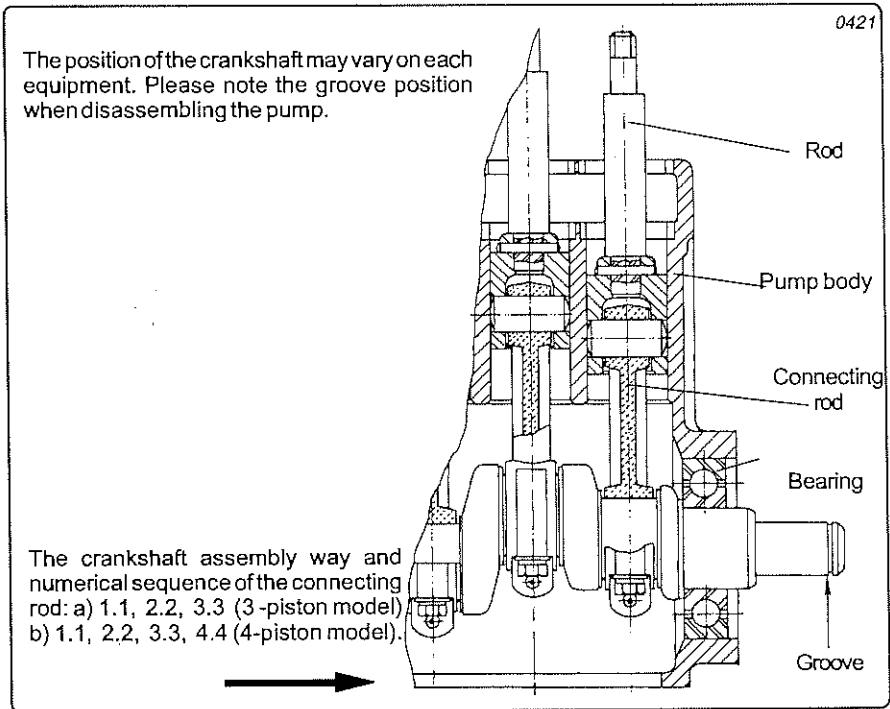

## ASSEMBLING THE PUMP

### 4- Flanges

- Lubricate with oil (API-SB ou superior SAE-30) the flanges housing and install the seal.
- Lubricate the seal with grease. Next mount the paper seal.
- Mount the flanges to the pump body and fit all screws.
- Tighten the screws with 1.6 kgf/m torque.

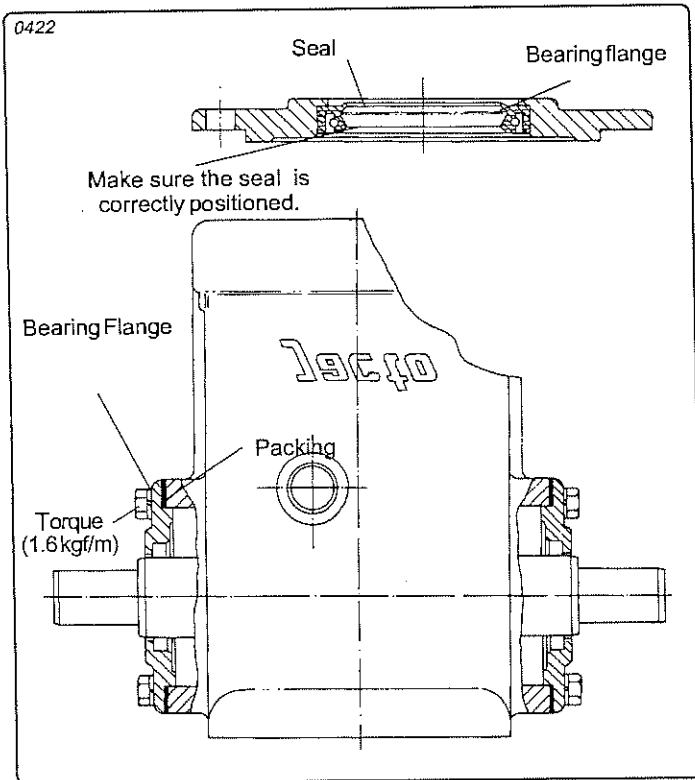



## ASSEMBLING THE PUMP

### 5-Sleeve guide and ceramic sleeve

-Install the seal, snap ring and scraper ring in the sleeve guide.

NOTE: Make sure the seal is positioned correctly.

- Position the paper seal and mount the sleeve guide to the pump body.

-Mount the piston cup and the piston to the ceramic liner.

- Position the paper seal on the liner guide and the piston cup base on the rod.

- Mount the sleeve with the piston cup, position the ring, install the brass washer, apply two drops of medium torque chemical bond to the rod thread and next fit the nut.

- Tighten the nut all the way with 4.5 kgf/m torque for the JP-75 & JP-100 pumps and 5.5 kgf/m torque for the JP-150 & JP-300 pumps.

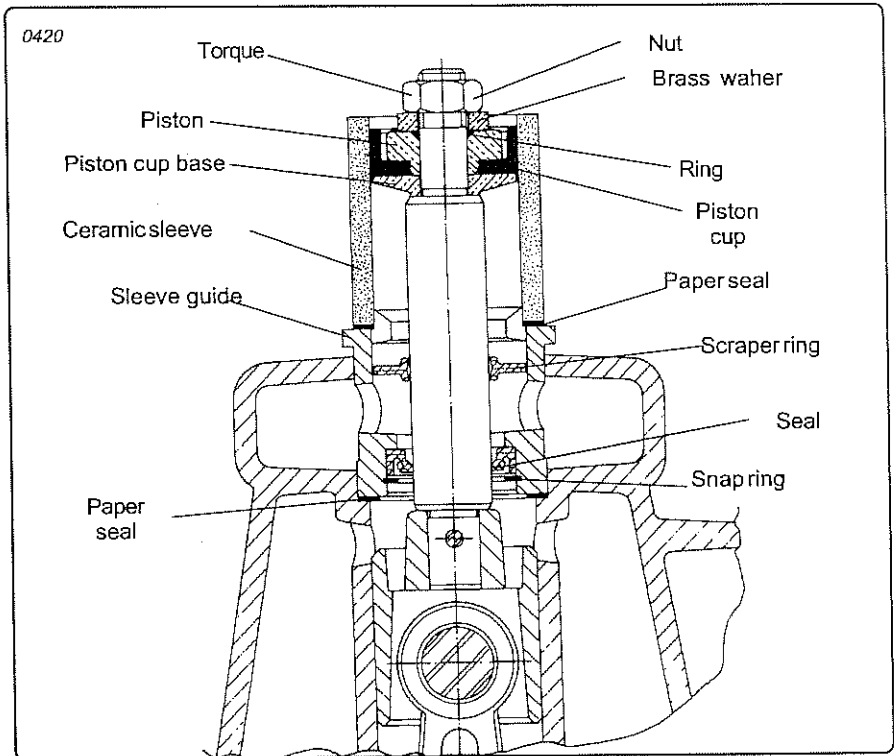

## ASSEMBLING THE PUMP

### 6- VALVES

- Fit the spring and the disc into the cage.
- Position the seat and the guide ring.
- Install the valve seal.

#### ATTENTION:

Make sure the parts are clean, free from impurities and mainly from abrasive chemicals

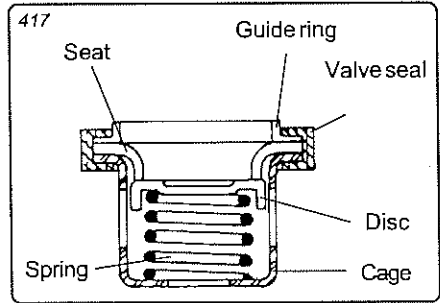

### 7- Head and valves cover

- Apply two drops of low torque chemical bond to the stud bolts and assemble.
- Mount the clip plate, install the lock washers, apply two drops of medium torque chemical bond to the stud bolt, fit all nuts and next tighten them with 4.5kgf/m for the JP-150 and JP-300 pump.

#### NOTE:

Always observe the arrow when mounting the head and the valves.

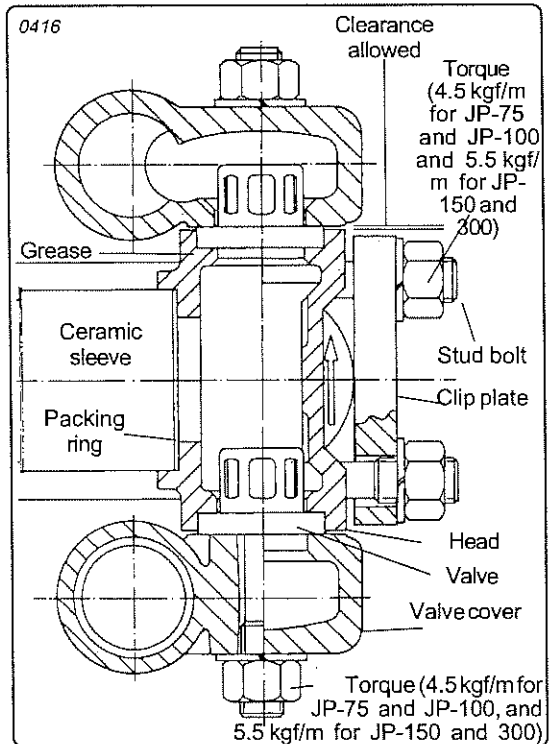

## ASSEMBLING THE PUMP

### 8- Plugs

-Mount the plugs with chemical bond or teflon tube sealer.

NOTE: The position of plugs and inlet and outlet nipples can vary according to the equipment. Please note their positions when disassembling the pump.

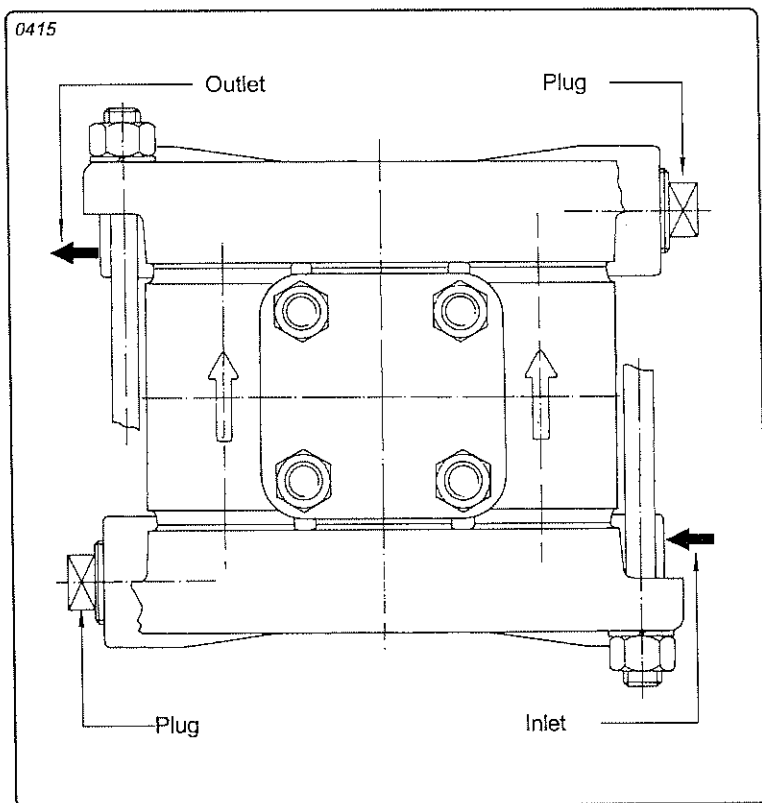

## ASSEMBLING THE PUMP

### 9- Mounting and Filling

- Install the cork seal and mount the cover
- Install the drain plug with the ring.
- Fill the pump with lubricating oil up to the level plug.

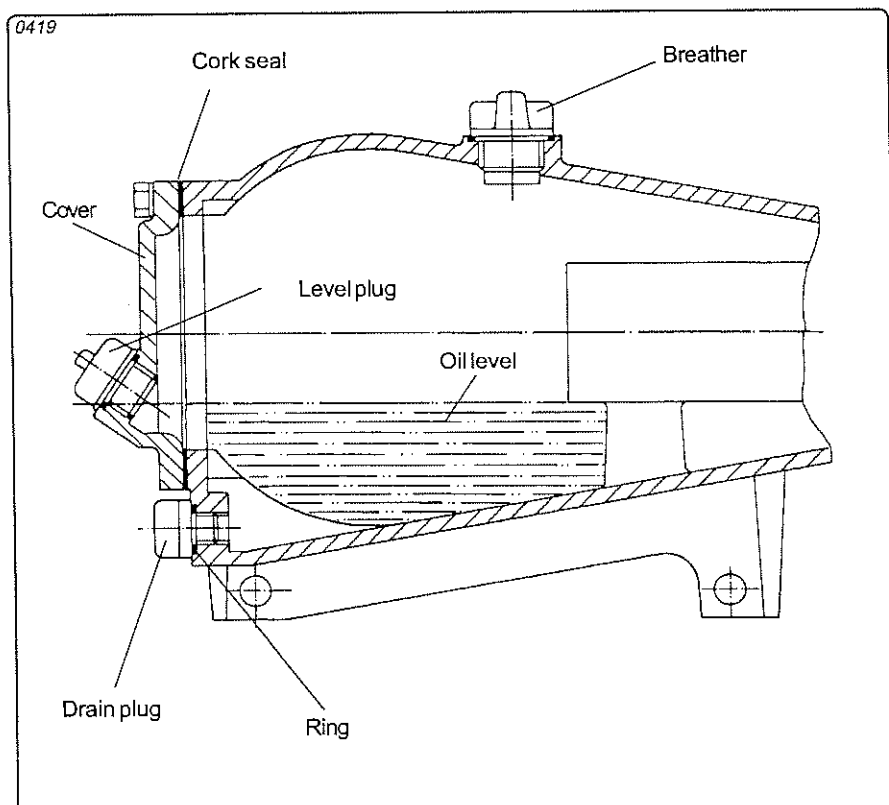

## ASSEMBLING THE PUMP

### 10-LUBRICATION

PRODUCT	PUMP	QUANTITY	FREQUENCY	RECOMMENDED PRODUCTS
Lubrication oil	JP-75	1.5 liters	1st change: 30 hours	API-SB or Superior SAE-30
	JP-100	2.0 liters		
	JP-150	2.5 liters	Further: every	
	JP-300	4.0 liters	100 h	

NOTE: The pump must be placed on a level surface.

- Fit the level plug and oil plug (breather).

- Test the pump with clean water under around 14 kgf/cm<sup>2</sup> (200 psi) during 10 minutes.

ATTENTION: Check for eventual leakages, vibrations, strange or excessive noise. In case of doubt, please do not hesitate to contact your Jacto dealer.

### WARNING

The maintenance instructions herein must only be applied to the pump after the expiration of the one-year warranty limit which starts in force on the purchase date. Within said period the user shall be authorized only to perform the replacement of parts subject to usual wear such as piston cups, seals and change of lubricating oil. This except, contact your Jacto dealer.

## **STATEMENT OF LIMITED WARRANTY**

MÁQUINAS AGRÍCOLAS JACTO S.A. warrants the equipment described herein and agrees to repair or replace parts and components which, under normal operation and wear, following the technical recommendations, show DEFECTS IN MATERIAL OR WORKMANSHIP.

**- WARRANTY PERIOD**

- One (1) year from the purchase date by the original retail purchaser.

**- WARRANTY APPLICATION:**

Jacto or its authorized representative shall honor this warranty, if any part or component shows confirmed defect in workmanship.

- IT SHALL BE UNDERSTOOD THAT THE REPLACEMENT OF ASSEMBLIES SHALL BE ONLY PERFORMED IN CASE THAT THE DEFECT CANNOT BE REPAIRED BY REPLACING PARTS AND/OR COMPONENTS.

**THIS WARRANTY IS NULL AND VOID IF:**

- Equipment is not used in accordance with the INSTRUCTIONS MANUAL, overwork or accidents,
- Improper preventive maintenance or performed by unauthorized people.
- Modification of the equipment in any way from the original design.
- Change, damage, or loss of the product identification plate.
- Utilization of parts and components not supplied by JACTO.

PRODUCT REGISTRATION CARD MUST BE COMPLETED BY THE ORIGINAL RETAIL PURCHASER, AND RETURNED TO JACTO DEALER WITHIN 30 DAYS OF THE PURCHASED DATE.

## **STATEMENT OF LIMITED WARRANTY**

### **WARRANTY EXCLUSIONS:**

- Parts considered as normal maintenance such as: filtering elements, belts, hoses, nozzles, pistons, pressure gauges, as well as usual maintenance, adjustments, retightening, lubrication and painting.
- Parts which show wear or tear due to use, UNLESS THEY SHOW DEFECTS IN WORKMANSHIP, ASSEMBLY OR MATERIAL.
- Hydraulic, lubricating oils and grease.
- Injuries of personal or material nature to the user, owner, or third parties.
- Additional charges resulting from paralyzation and repair of the equipment.
- Freight charges, pick up and delivery charges.
- Damages of any nature resulting from action of gases or liquids used in the equipment.

### **GENERAL INFORMATION:**

- Defective parts replaced under warranty period shall be property of JACTO.
- Eventual delays in performing services do not confer to the owner the right to indemnity or to extension of the warranty period.
- JACTO reserves the right to change its products or to interrupt manufacturing the equipment.
- THIS LIMITED WARRANTY shall be understood by its expressed terms, and no one in anyway subject to JACTO shall be authorized to modify or amplify the conditions prescribed herein.
- In case of need for warranty request, call for the authorized dealer supplying all information required for a prompt compliance. Do not forget the identification of the equipment, total hours of work, and the noticed defect.

FOR THIS WARRANTY TO BECOME EFFECTIVE THE PRODUCT REGISTRATION CARD FOUND IN THE INSTRUCTION MANUAL MUST BE FILLED IN AND RETURNED TO YOUR JACTO DEALER. THIS CARD MUST BE SIGNED BY THE ORIGINAL RETAIL BUYER, INDICATING THAT HE HAS READ AND UNDERSTOOD ALL SAFETY AND OPERATIONAL INTRUCTIONS IN THE MANUAL. FURTHER THE RETAILING DEALER HAS EXPLAINED TO THE ORIGINAL RETAIL BUYER ALL SAFETY INSTRUCTIONS. IN NO CASE WILL WARRANTY BE SUPPLIED UNTIL THIS CARD, PROPERLY COMPLETED AND SIGNED, IS ON FILE WITH JACTO RETAILING DEALER. A COPY OF THE PRODUCT REGISTRATION CARD SHOULD BE KEPT BY THE ORIGINAL OWNER, AS WELL AS THE COMMERCIAL INVOICE.



**MÁQUINAS AGRÍCOLAS JACTO S.A.**  
Rua Dr. Luiz Miranda, 1650  
17580-000 - Pompéia - SP - Brazil  
Tel.: +55 14 452-1811 - Fax: +55 14 452-1306  
E-mail: [jacto@jacto.com.br](mailto:jacto@jacto.com.br)

08/99 - 750935 - MI-0097