

**JSC-5000 A
ELECTRONIC
SPRAYERS CONTROL**

English version - MI_USA-0269

**EDITION - 05/2005
CODE - 750190**

Operator's Manual



MÁQUINAS AGRÍCOLAS JACTO S.A.

Rua Dr. Luiz Miranda, 1650
17580-000 - Pompéia - SP - Brasil

Tel.: +55 14 3405-2100

Fax: +55 14 3452-1916

E-mail: export@jacto.com.br

Home page: www.jacto.com.br

TABLE OF CONTENTS

- INTRODUCTION	04
- OPERATION	06
- PANEL	06
- 1- "ON/OFF" SWITCH	07
- 2- "AUTOMATIC/MANUAL" SWITCH	07
- 3- "FUNCTION "SWITCH"	07
- 4- DISPLAY AVAILABLE FUNCTIONS	07
- 5- LIQUID CRYSTAL DISPLAY	08
- 6- "+ / -" SWITCH	08
- 7- "RESET" SWITCH	09
- ALARMS AND ERRORS VISUALIZATION DURING USE	10
- CALIBRATION	11
- PROGRAMMING	
- ACCESSING THE CONTROL PROGRAM	15
- ADJUSTING THE FLOWMETER	16
- ADJUSTING THE SPEEDMETER	18
- ADJUSTING THE BOOM SECTION LENGTH	19
- TEST/SETUP	21
- MAINTENANCE	22
- CLEANING THE FLOWMETER	22
- MANUAL PRESSURE ADJUSTMENT	23
- CONTROL LEVERS MANUAL OPERATION	23
- TESTING THE BOOM SECTIONS SENSORS AND SOUND ALARM	25
- DIAGNOSING ELECTRONIC PROBLEMS	26
- DIAGNOSING THE ALARMS WHEN PROGRAMMING/ADJUSTING	27
- DIAGNOSING DEFECTS ON THE SPRAYERS EQUIPPED WITH JSC-5000 A	28
- INSTALLING THE JSC-5000 A	29
- INSTALLING THE JEC-3200/ JEC-3400/ ELECTRIC PANEL III	30
- POSITIONING THE JEC-3200/ JEC-3400/ ELECTRIC PANEL III AND JSC-5000 A	31
STATEMENT OF LIMITED WARRANTY	32

INTRODUCTION

JSC-5000 ELECTRONIC SPRAYER CONTROL

OPERATION, CALIBRATION AND MAINTENANCE MANUAL

Congratulations,

You have just acquired a high-tech equipment, which will make easier your phitosanitary treatment and increase your productivity.

With the **JSC-5000 A**, the operator will no longer waste time adjusting and checking the sprayer.

JSC-5000 A ELECTRONIC SPRAYER CONTROL

This is a system that automatically calibrates the sprayer and ensures constant liquid quantity distributed per area, regardless of the speed fluctuations within the same gear. The recommended speed for operating with the JSC-5000 A is from 2.17 to 18.64 mph.

With the introduction of the JSC-5000 A, the farmer will save time and chemicals. 10% errors are practically unavoidable in manual calibrations, which are per trial and error. Besides the error in the calibrations, the tractor speed fluctuations also affect the result. The JSC-5000 A compensates all fluctuations on the working speed and keeps constant liquid volume per area. Using the JSC-5000 A provides a fluctuation of up to 5% only on the area calculation, which means the liquid applied per area is not compromised because the calculations are distincts, being this fluctuation obtained by the computer due to adverse conditions, such as: tires pressure, sandy soil, sprayers surmounting raised grounds, tires slip, etc.

With the JSC-5000 A, the operator must input how many liters of spray mixture he intends to apply per hectare, and the control will regulate the pressure depending on the working speed to ensure the liters input by the operator. It is important to point out that for this regulation to be precise, all the spray circuit must be very clean.

Besides automatically calibrating the sprayer, the JSC-5000 A provides to the farmer important data to handle the spray application. With soft-touch keys, the screen displays the following information: mean spraying, operating time, distance traveled with spray on, liters applied per minute, partial treated area, total treated area, partial sprayed volume and total sprayed volume. All this information is very useful for handling the phitosanitary treatment task and decisions making. During the operation, the screen continuously displays the operating speed and spraying volume.

Another function of the JSC-5000 A is the manual calibration. Should there be any problem in the computer system, the operator will not have to interrupt the application. Just select the manual function and continue to spray normally until the computer system is repaired. This enables the farmer to make use of all precision advantages of the computer system, without losing the advantages of the manual adjustment simplicity.

INTRODUCTION

ADVANTAGES OF THE JSC-5000 A

1. Simplifies the sprayer calibration, eliminating the operations to calculate the operating speed and to calibrate.

NOTE: Every time you replace nozzles or every week, check if the actual nozzles flow rate on the boom corresponds to the flow rate input in the control display (Function: Prog./Cal.). This procedure is described in the Section: PROGRAMMING - ALTERING THE FLOWMETER CONSTANT.

2. Improves substantially the calibration precision.

3. Compensates automatically the fluctuations on the operating speed.

4. Compensates automatically the fluctuations on the nozzles flow rate caused by wear or fluctuations on the pressure.

5. Provides a series of relevant operational data.

6. Eliminates the dependence on the pressure gauge as a reference for pressure and flow rate.

OPERATION

For controlling the application, the JSC-5000 A calculates the sprayer speed (mph) and the flow rate (gpm) being sprayed.

Observe the following formula:

$$\text{gpa} = \frac{\text{gpm} \times 495}{\text{mph} \times \text{s}}$$

- Where:
- gpm = Total nozzle flow rate on the boom
 - 495 = Constant
 - mph = Sprayer speed
 - s = Spray band width in feet

The computer calculates the volume being applied (gpa). If the volume is not equal to that desired, the computer alters the pressure regulator setting to adjust the flow rate (gpm) until getting the desired volume.

For the JSC-5000 A to alter the pressure regulator setting, the spray control CRC-200-E has an electric motor coupled to the pressure regulator assembly. If the computer cannot correct the spraying volume, or if some sensors show problems, a sound alarm will indicate the fault.

PANEL

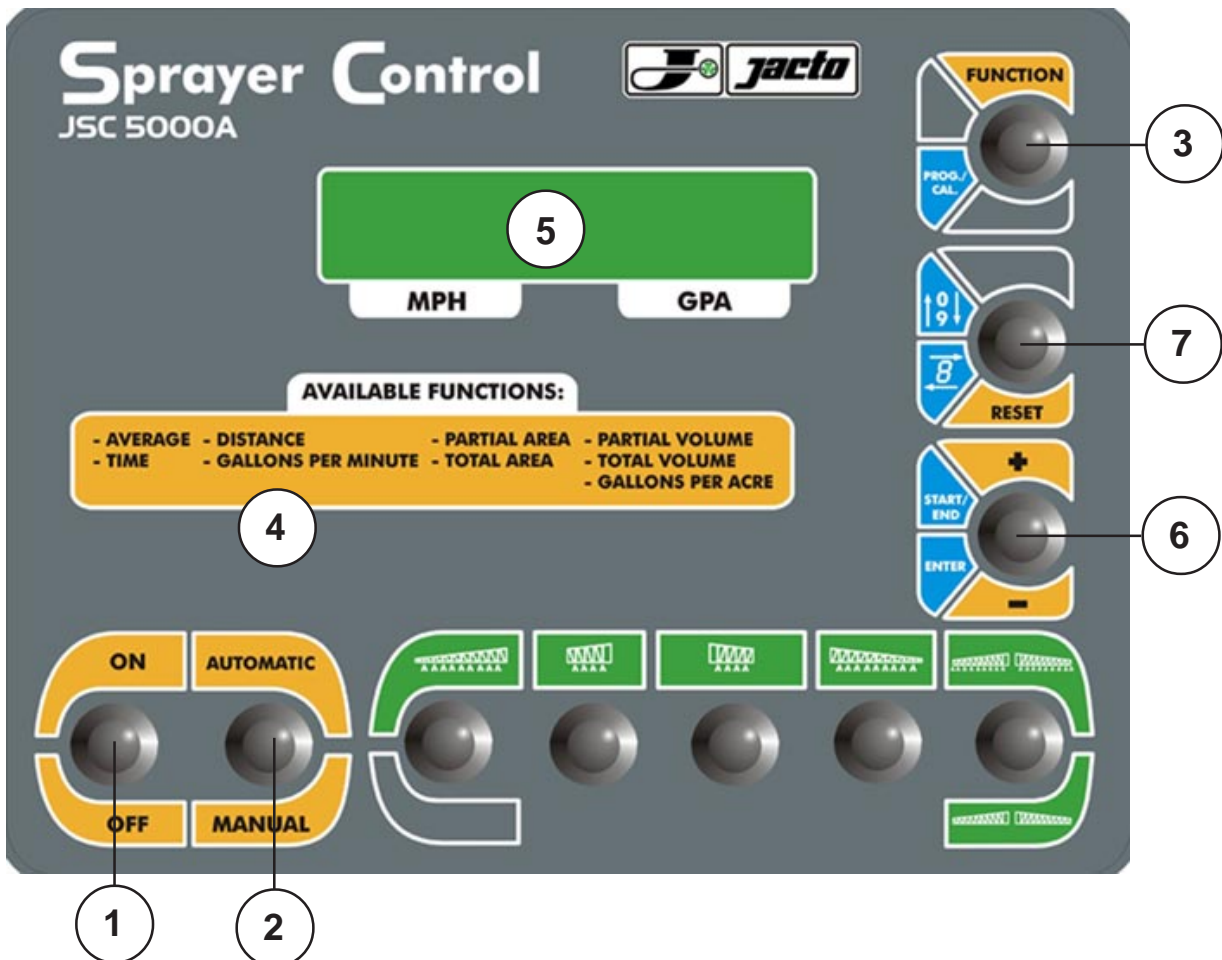

OPERATION



1- "ON/OFF" SWITCH

ATTENTION: This switch must remain "ON" during the operation, otherwise the control will not store the accumulated data of area, volume, etc.

2- "AUTOMATIC/MANUAL SWITCH"



MANUAL: On this position, the sprayer is operated mechanically and the control will only monitor the application.

AUTOMATIC: On this position, the control is operated electronically, controlling the flow rate and maintaining constant the spraying volume (gpa).

3- "FUNCTION" SWITCH



This switch displays the control available functions. By moving it up and down the functions appears on the top line of the screen one by one following the same order as printed on the panel.

Observe that, in turning on the JSC-5000 A, the first function it displays is: "TIME". Also note that, if the function "ADJ. gpa" is chosen and 30 seconds pass without altering this function, the display will go the function TIME.

This is designed to prevent accidental alteration when the function "ADJ. gpa" is not being used.

NOTE: On the right top of the panel, besides the FUNCTION switch, there is a blue square with the indication "Prog./Cal.", which means "Program and Adjustment. To access this information, there is a special procedure which is described in the section PROGRAMMING.

4- DISPLAY AVAILABLE FUNCTIONS



The functions can be accessed by moving the lever of the FUNCTION SWITCH (NO. 3).

- MEAN: when in use, the sprayer calculates the average spraying volume (gpa) and speed (mph).

NOTE: whenever you restart the spraying job, these values are erased for new data. The minimum time for the control to calculate the average is 30 seconds.

- TIME: actual spraying time (hours)

- DISTANCE: distance (miles) run with nozzles turned on.

OPERATION

- GALLONS PER MINUTE: total sprayed by all nozzles during one minute (gpm).
- PARTIAL AREA: indicates the area covered per the sprayer (acre). This function can be used to record the worked area per day, per stripe of land, etc.
- TOTAL AREA: indicates the total area accumulated in hectares (acre). This function can be used to record the worked area for long periods.
- PARTIAL VOLUME: indicates the quantity of chemical mixture applied (gallons). This function can be used to indicate the quantity of chemical mixture applied per day, per stripe of land, etc.
- TOTAL VOLUME: this function indicates the quantity of chemical mixture applied for long periods.
- GALLONS PER ACRE: in this function you can program the desired application rate in gpa.

5- LIQUID CRYSTAL DISPLAY

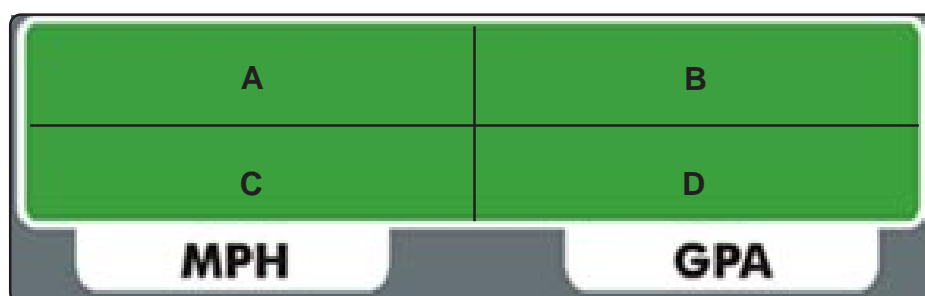

To make easier to explain the values that appear in the display, we divided it in 4 parts: A, B, C and D.

A - It shows the function that has been accessed.

B - It shows the value corresponding to the function being used.

Ex: If "A" displays the function "Gallons per acre", then "B" will show the volume calibrated in gpa.

C- It shows the operating speed (mph). And if the AUTOMATIC/MANUAL switch is set to MANUAL operation, the letters "MA" will also appear intermittently.

D- It shows the instantaneous value in gpa being applied, which is the actual spraying value.

6- "+ / -" SWITCH



This switch has the yellow and blue colors, each corresponding to different functions.

The functions corresponding to the blue color are described in the section PROGRAMMING.

Here we will explain the signals "+" and "-" located in the yellow part.

To use this switch, it is necessary to set the FUNCTION to ADJ gpa.

Once it is in the function "gpa", move the switch "+ -" upward or downward and note that the value corresponding to gpa changes. Keep moving the switch until it shows the desired volume.

The value input will correspond to the application rate (gpa) that the control will adjust after completing other phases of the calibration.

NOTE: The values of this switch ranges from 15 to 2,000 (L/ha).

OPERATION

7- "RESET" SWITCH



This switch also has the blue and yellow colors, each corresponding to different functions.

The functions corresponding to the blue color are described in the section PROGRAMMING.

Except the values in "gpa" and "gpm", this switch resets all other values given by the FUNCTION switch.

NOTE: To reset, it is necessary to hold the switch 5 seconds.

Example:

After a spraying period, it is possible to know the distance run, the quantity of sprayed hectares, the amount of sprayed chemical mixture, etc.

If you set the FUNCTION switch to "Total Volume" or "Partial Volume", you will note that the values are the same.

If you have to change the area and wish to know what will be the sprayed volume, set the FUNCTION switch to "Partial Volume". Then, move this switch to reset this value.

After spraying the new area, you will note that the "Total Volume" will continue to be accumulative, and the "Partial Volume" will have the value sprayed in the area you have monitored.

OPERATION

POSSIBLE ERRORS ALARMS AND VISUALIZATION DURING USE

NOTE: Both alarms and errors are only possible if the control is set to AUTOMATIC operation.

In case of any alarm, for the JSC-5000 A to continue to operate normally, it is necessary to set the switch no. 2 (page 06) to MANUAL operation. After solving the problem, set the switch to AUTOMATIC operation again. If it remains set to the MANUAL operation, there will be a sound alarm during 20 seconds.

1- BATTERY ERROR HIGH VOLT.

Possible cause

- Problem on the sprayer electric circuit
(alternator voltage regulator).

2- BATTERY ERROR LOW VOLT.

Possible cause

- Problem on the sprayer electric circuit
(alternator voltage regulator).

3- CONTROL ERROR LOW P. LIMIT

Possible cause

- Spraying volume not compatible with the operating
speed and nozzle type.

4- CONTROL ERROR HIGH P. LIMIT

Possible causes

- Spraying volume not compatible with the operating
speed and nozzle type.
- Spray circuit filters with restriction.

5- FAULT FLOWMETER OR DRY PUMP

Possible causes

- Problems on the flow meter.
- Sprayer running for long time without water in the
tank.

6- MEMORY ERROR

Possible cause

- Electronic problem on the JSC-5000 A computer.

7- BOOM SECTION ADJUSTMENT ERROR

Possible cause

- Calibration error in the spraying area
(Masterflow control return).
- Some nozzles are off or clogged up.

8- CONTROL ERROR

Possible cause

- JSC-5000 A is not providing accuracy.

9- LOW WATER LEVEL

Possible cause

- In the first line of the display the message "LOW WATER
LEVEL" appears alternating with the function in use. After
one minute, the control will beep.

CALIBRATION

For calibrating the sprayer with the electronic control, it must be running, besides the "Automatic/Manual" switch (no. 2 - page 06) must be set to "Manual" (manual operation).

To use the sprayer control, you must calibrate the return of every spray section and input the desired value of "gpa" in the FUNCTION gpa. And this value must be compatible with the following:

1- The desired application rate (gpa) must be within the recommended operating pressure range for the nozzle being used.

For example: to apply 10.68gpa at 6.21 mph with the nozzle API-110.02, this nozzle must provide a flow rate within the pressure range: 14.2 to 56.89 psi.

2- The speed (mph) must be within the recommended use range for the nozzle type being used.

NOTE: Sometimes the volume will not be appropriate to the speed and nozzle pressure. In this case, the operator must review the related instructions.

CALIBRATING THE BOOM SECTIONS

- Put clean water in the spray tank.
- The "On/Off" switch (no. 1 - page 06) must be set to "On". The "Automatic/Manual" switch (no. 2) must be set to "Manual".
- Run the sprayer.
- Accelerate the engine until getting 1,800 rpm (UNIPOINT).
- For tractor-driven sprayers the rotation at the PTO must be 540 rpm.
- Set all switches of boom section and the "Relief" switch (no. 3 - figure below) to "On" (to turn on the spray).

IMPORTANT: DO NOT ALTER ROTATION UNTIL YOU FINISH THE CALIBRATION.

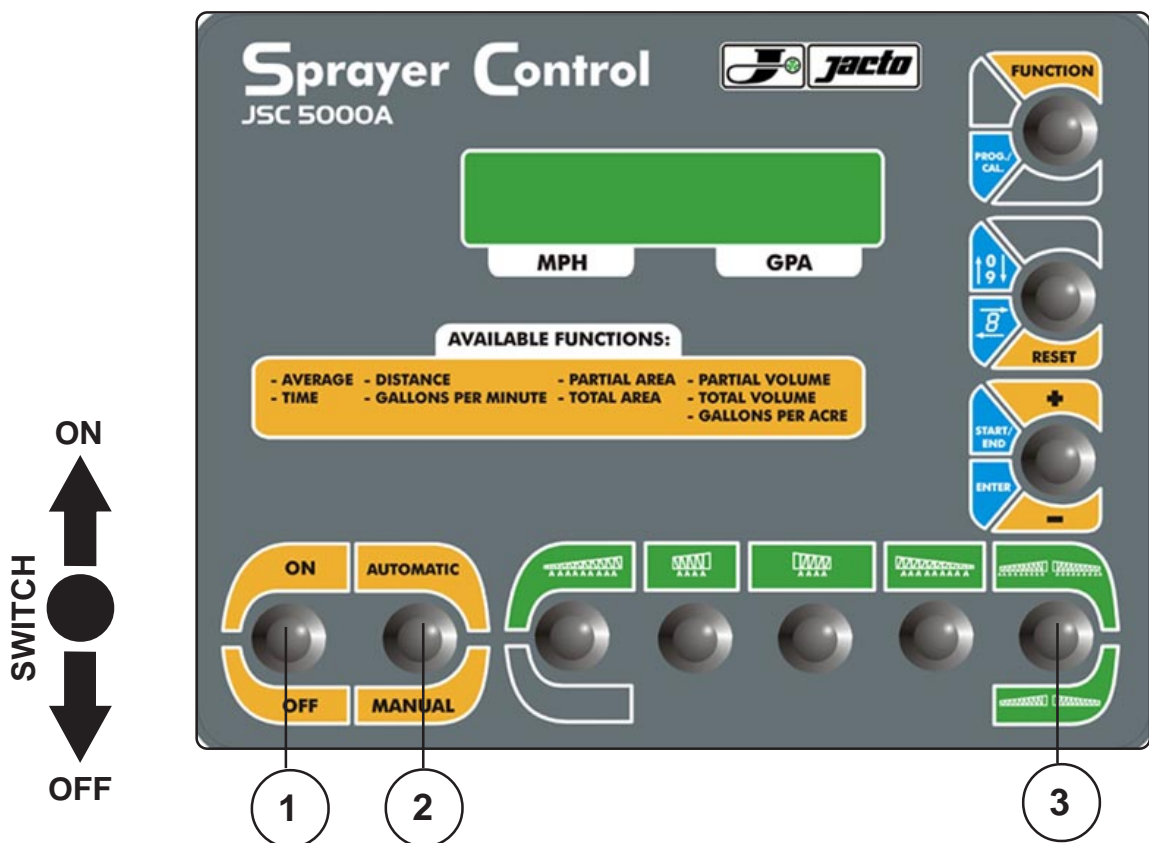

CALIBRATION

1- Move the switch (1) to turn on the spray to the booms (relief switch P).

- Move the Manual Pressure Adjustment switch (2) to set a referential pressure (ex.: 3.5 kgf/cm² - 50 psi).

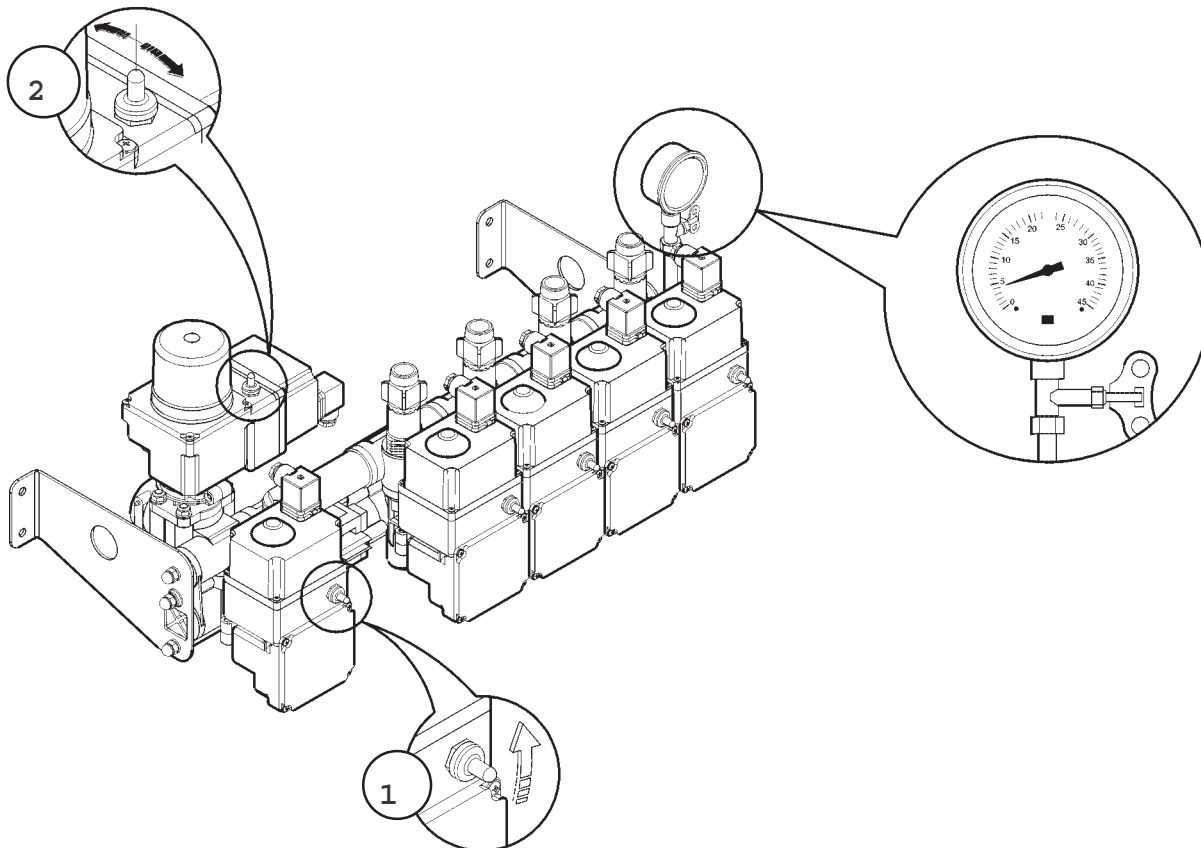

ATTENTION: Position the pressure regulator knob at the referential pressure for calibrating the boom sections (ex.: 50 psi).

CALIBRATING THE BOOM SECTION PRESSURE

2-Keep the initial rotation (540 rpm for the spray pump) and the spray on to all boom sections.

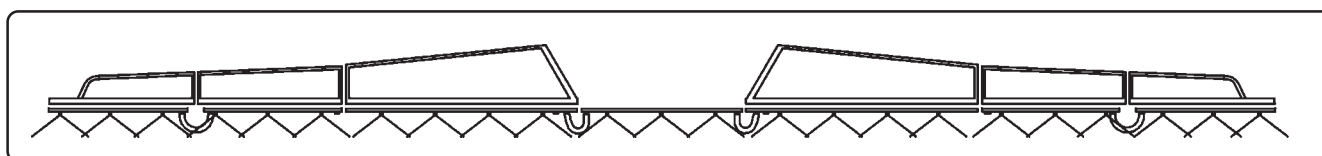
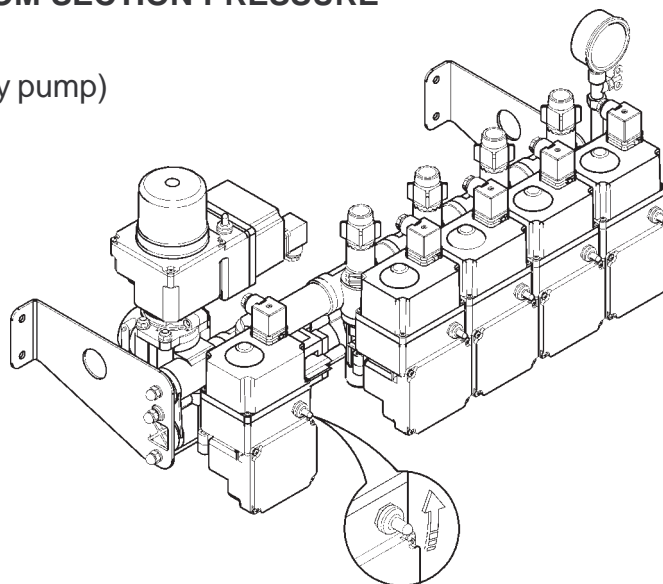

CALIBRATION

3-Check the pressure in the pressure gauge (50 psi).

4-Select one of the boom section (ex.: boom section B), and move the switch to turn off the spray.

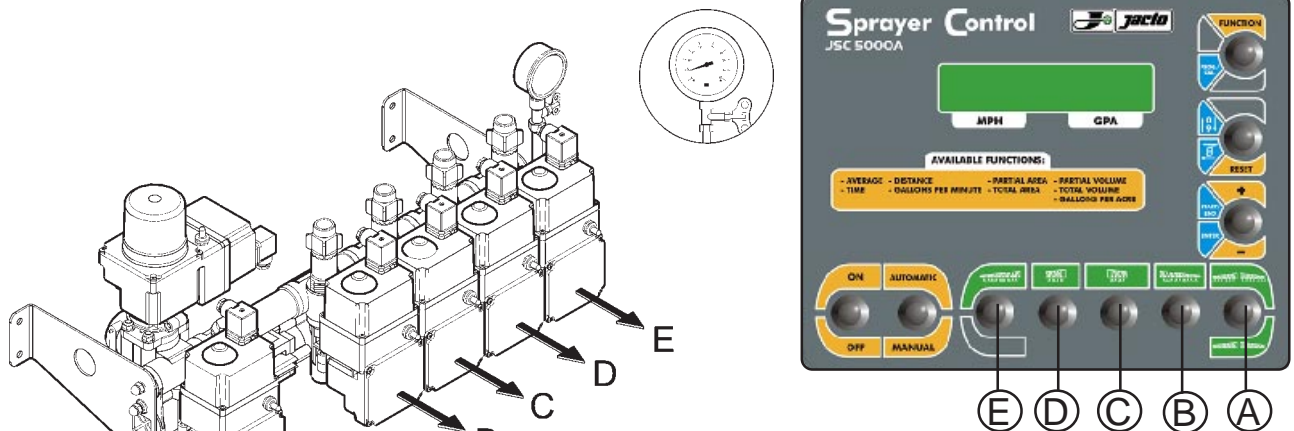

NOTE: The spray to the other boom sections must remain on.

No spray to the boom section B

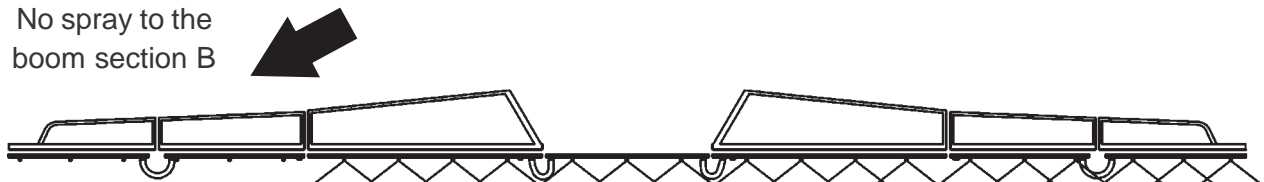

5-Check for pressure fluctuation in the pressure gauge (50 psi). If it has fluctuated , proceed as follows:

- Loosen the locking screw.

-Turn on the boom section B switch as shown below. While holding it on, turn the knob clockwise all the way. Then, turn it counterclockwise until reaching the pressure balance.

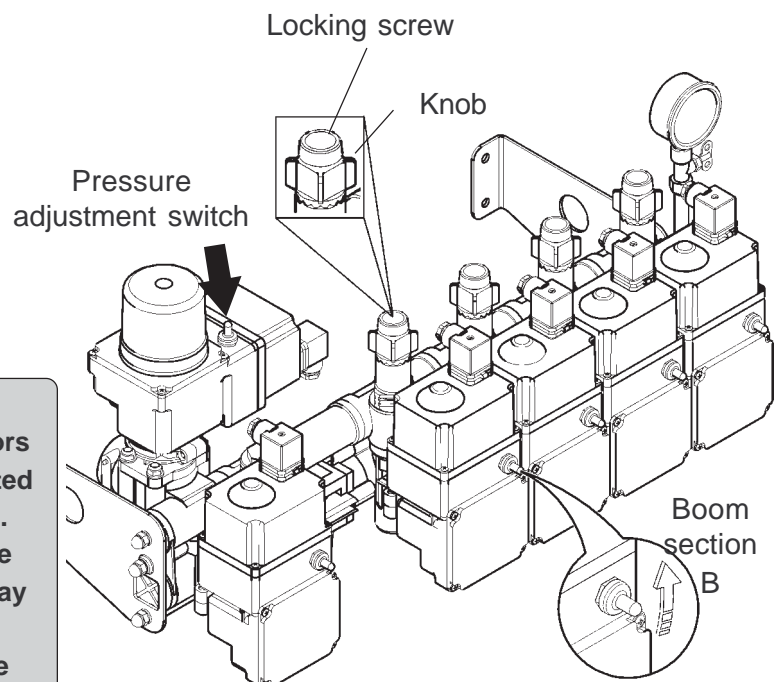

NOTE:

The switches to actuate the electric motors of the control blocks must only be operated in case of need to calibrate the control. During use, the turning on and off of the spray will be controlled through the spray actuation panel. Only the pressure adjustment cannot be done through the spray actuation control.

CALIBRATION

NOTE: The pressure must be the same as previously indicated in the pressure gauge (50 psi) when all nozzles of this boom section were on.

- Once the pressure gauge is calibrated, release the motor actuation switch and tighten the locking screw.
- Repeat this operation on all boom sections in order to maintain constant pressure along the boom, regardless of the number of boom sections turned on.

ATTENTION: Do not change the PTO rotation while checking in order not to change the nozzle pressure, which fact will alter the nozzles flow rate.

- Then, set the "FUNCTION" switch to "gpa".
- Through the "+ -" switch, input the desired application rate. Ex.: 10.68 gpa.
- Set the "Automatic/Manual" switch to "Automatic" (automatic operation) and start the application.

NOTE: In case of need to change the gear or even the operating rotation, note that the control will adjust the pressure so that the application rate is maintained (10.68 gpa).

If during this operation there is incompatibility among the volume, speed and pressure, the control will emit a sound signal indicating control failure.

PROGRAMMING

ACCESSING THE CONTROL PROGRAM

The JSC-5000 A comes off the assembly line already programmed.

In case you have to alter the program or even service its electronic system, you should access the program as described below.

ACCESSING THE JSC-5000 A PROGRAM AND CALIBRATION

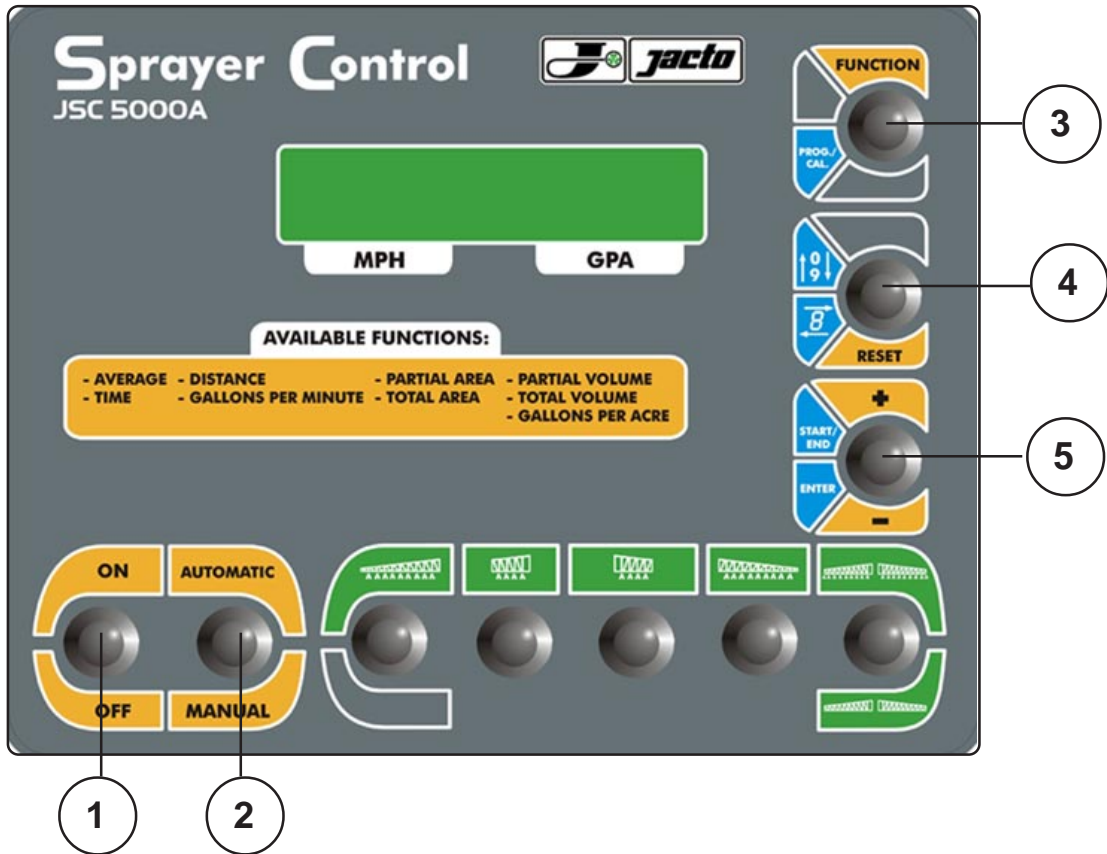

To access the function "Program/Calibration", turn on the control through the switch no. 1 and set the switch no. 2 to "Manual". It is also necessary to move the "Prog./Cal." switch no. 3 downward and the "Reset" switch no. 4 upward at the same time and hold them for 10 seconds. Then, note that the function "Prog./Cal." will be displayed.

NOTE: The information to be explained here will be accessed in the control through the switches with the functions corresponding to the blue color.

TO MAKE EASIER TO UNDERSTAND, THESE SWITCHES WILL BE NO. 1, 2, 3, 4 AND 5

Switch no. 1 - It turns on/off the system.

Switch no. 2 - It selects the mode of operation: manual or automatic.

Switch no. 3 - It accesses the options to program and check the following functions:

1st - "Flow Rate Adj", where 'Adj.' means "adjustment".

2nd - "Speed Adjustment".

3rd - "Boom Section Length Adj.", where "Adj." means "adjustment".

4th - "Test/Setup" - to check the running of the wheel sensors, flowmeter and pressure adjustment electric motor.

NOTE: Once set in the function "Prog./Cal." it is not possible return to the last function accessed. If you have advanced to the next function, it will be necessary to repeat the operation to input the Program/Calibration.

PROGRAMMING

- Switch no. 4 - It changes the following values:
- Flowmeter constant (Flow Rate Adj.)
 - Speed constant (Speed Adj.)
 - Boom section length constant (Boom Section Length Adj.)

Switch no. 5 - It memorizes the constant values input through the switch no. 4.

1- ADJUSTING THE FLOWMETER

NOTE: Before calibrating the flowmeter, clean and wash the sprayer's circuit: tank, control, nozzles, tubes, filters, etc.

It is a mechanism fitted in the sprayer pressure line which measures the flow rate in gpm that passes through the control on the way to the spray boom. The flowmeter constant is the ratio of pulse per liter sprayed by the nozzles.

ATTENTION: This value can vary from a mechanism to another. In inputting this value in the control memory, make sure it is the most precise possible in order to prevent errors in the reading of flow rate and sprayed volume.

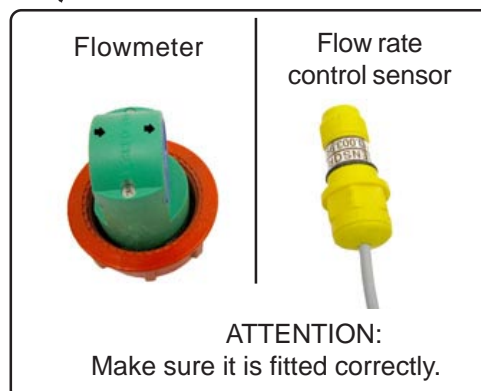
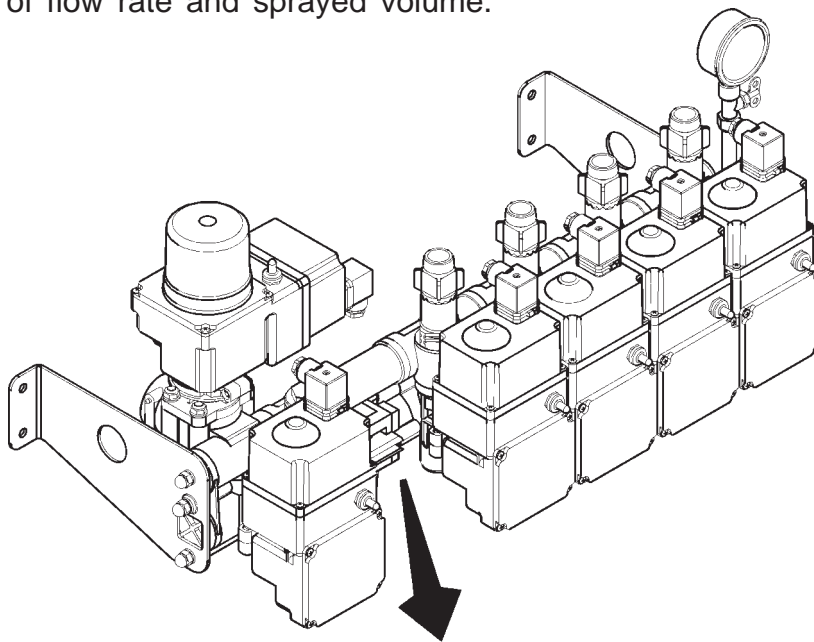

PROGRAMMING

Whenever it is necessary to replace the flowmeter, the package will bear the constant value to be input in the control memory. As this value can vary after fitting the flowmeter, it is very important to check for its accuracy, because it is through this and other constant values that the control will give data on the application.

INPUTTING THE FLOWMETER CONSTANT VALUE IN THE CONTROL MEMORY

- Access the function "Prog./Cal." following the instructions in the page 15.
- Move the switch no. 3 (page 15) downward.
- Note that the instruction "Flow Rate Adj." will be displayed.
- Then, move the switch no. 5 (page 15) downward.

On the top of the display appears the boom flow rate in gpm.

On the bottom of the display appears the flowmeter constant value.

- Move the switch no. 4 downward and note that the last number of the constant starts to flash  . In case of need to change it, move this switch upward. If it is not necessary to change this value but the value before it, move this switch downward to change the unit, and then upward to change the corresponding unit value until obtaining the desired value.

NOTE: Move upward to change the unit and downward to change the unit value.

- After inputting the values, move the switch no. 5 downward and hold it for some seconds. Note that it will display "Wait", then "Adj. OK". This way, the new constant value is programmed.

CHECKING IF THE FLOWMETER CONSTANT IS CORRECT

- Access the function "Program".
- Set all the control levers to the position Spraying.
- Adjust the pressure according to the nozzle type (Manual Pressure Adjustment Switch).

NOTE: Make sure the engine rotation remains the same while checking.

- Collect the nozzle flow rate on the boom (total flow rate).

NOTE: The collected flow rate must be the same as shown in the display. If not, you should correct the constant value on the electronic control.

IMPORTANT: Before altering the constant value, check if the flowmeter is clean and collect many times the boom flow rate. This value is extremely important for the calibration and reading of the sprayer control. Check also whether the engine rotation did not fluctuate.

PROGRAMMING

ALTERING THE FLOWMETER CONSTANT

Example:

Constant recorded in the electronic control	615
Flow rate on the display	7.13 gpm
Flow rate checked on the boom	7.39 gpm
New constant value	(X)

$X = \frac{615 \times 7.13}{7.39} = 593$ **X = 593**

NOTE: To quit the program, move the switch no. 3 downward four times.

2- ADJUSTING THE SPEEDMETER

On the front wheels of the Uniport (front) and on the wheels of the Columbia/Advance sprayers equipped with electronic control there are steel discs with bores. The disc diameter as well as the bores diameter and position are gauged and must be exact for the perfect operation of the system. Therefore, never try reconditioning, but replace it by original one.

There is a sensor for each disc mounted on the wheels, so the sprayer speed is adjusted according to the number of bores passing through the sensor.

Before adjusting, check the tires condition and pressure. Preferably, the tires should be original and calibrated with the recommended pressure for each type of equipment.

IMPORTANT: If you adjust the speed with the tires not calibrated as recommended, there will be a variation in relation to the constant and actual speed when you calibrate them as specified in the operator's manual, since the tires diameter and perimeter will change, likewise the number of turns (mile/linear). The same problem will occur if you do not use original tires, and you will have to adjust the value again.

PROCEDURE

- Access the function "Prog./Cal" as described in the page 15.
- Move the switch no. 3 downward twice (page 13).
- Note that the display will show: "Speed Adjustment".
- Then, move the switch no. 5 downward (page 15) and the display will show "Distance = 50m " (unchangeable value) on the top and the speed adjustment constant on the bottom.
- Stop the sprayer on a level ground, free from obstacles and curves, at an exact distance of 50 meter long.
- Engage the PTO at 540 rpm (for the Columbia/Advance line sprayers). This rotation can even change, but the sprayer must never move backward.

NOTE: The calibration gear should be as much slow as possible for easily marking off the 164 feet.

PROGRAMMING

NOTE: The engine rotation can fluctuate because the speed is not set considering the Distance/Time but the number of revolution the wheel sensor records through the bores existing on the wheel discs in the path of 164 feet.

- Choose a referential point on the sprayer.
- At the time this referential point passes by the initial point to the 164 feet, move the switch no. 5 upward (page 15) to start the speed adjustment.
- At the time the same referential point reaches 164 feet, move the switch no. 5 upward again (page 15) to finish the speed adjustment.

NOTE: The value displayed will correspond to the speed constant.

POSSIBLE ERRORS WHILE ADJUSTING THE SPEED

A- MESSAGE: FAULT WHEEL SENSOR

This message will appear when one or both sensors are not functioning properly.

Possible causes:

- Defective wheel sensor, or wheel sensor placed more distant from the wheel disc than recommended (correct distance: 0.11 to 0.12 inch).
- Damaged wheel disc.
- Poor contact on connection or terminals.

B- MESSAGE: WHEEL DIAMETER ERROR

- Tires pressure other than specified.
- Tires of different brands.

C- MESSAGE: CONSTANT ERROR

This message will appear when the number of pulses collected from the wheel in the path of 164 feet is below or above the value programmed in the JCS-5000 A control.

Possible causes:

- The 164 feet distance was not measured correctly.
- Tires model very different from the specified.

NOTE: To quit the program, move the switch no. 3 downward three times.

3- ADJUSTING THE BOOM SECTION LENGTH

There is no operational factor that can alter these values and make the sprayer operate with unreal data, unless the operator or a third person accesses the function and input values that do not correspond to the sprayer characteristics. These values are input in the sprayer control memory, since it is necessary to make these values compatible with the nozzle spacing on the boom, considering that there are three possible nozzle spacings: 13.77, 15.74 or 19.68 inch.

MEASURING EACH BOOM SECTION LENGTH

1st. You should verify what is the relation between the control switch and boom section. You can do this by setting the relief switch no. 1 to turn on the spray to the boom and setting other switches to turn off the spray. Then, operate any of the other switches to turn on the spray to any of the boom sections and identify the boom section corresponding to this switch. Repeat this operation with other switches in order to prevent fault in spraying

2nd. To identify every boom section length, just count the nozzles on the boom section and multiply this number by the value corresponding to the nozzle spacing (inch).

PROGRAMMING

Ex: Columbia Cross with JP-100 pump

Total nozzles = 37 - Nozzle spacing = 19.68 inch

Boom sections:

A = 9 nozzles x 19.68 inch = 177.12 inch

B = 9 nozzles x 19.68 inch = 177.12 inch

C = 10 nozzles x 19.68 inch = 196 inch

D = 9 nozzles x 19.68 inch = 177.12 inch

TOTAL = 37 NOZZLES = 727.36 inch

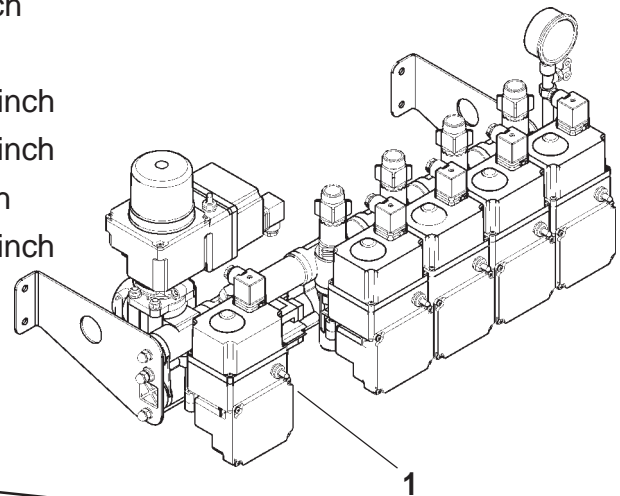
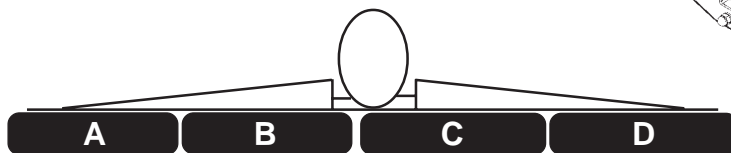

ACCESSING THESE VALUES

- Access the function "Prog./Cal." as described in the page 15.
- Set all control levers to turn off the spray.
- Move the switch no. 3 downward three times (page 15).
- Note that the display will show "Boom Section Length Adj."
- Then, move the switch no. 5 (page 15), and the display will show: "Turn on Section".
- Set the lever corresponding to the boom section to be adjusted to turn on the spray. The display will automatically show a value, which can vary according to the boom length and nozzle spacings.

- To change this value, move the switch no. 4 downward (page 15), which will make the last number flash. Then, proceed as follows:

- a) move this switch upward to change this value
- b) move this switch downward to make the number before flash.

- After inputting the values, move the switch no. 5 downward (page 15) and the display will show "Adj. OK".

- Set the boom section switch back to turn off the spray .
- Repeat this operation with other boom sections.

NOTE: Only one boom section can be adjusted every time. If you operate more than one switch at the same time, the display will show an error message.

The display will also show the letter "P" when the quick relief switch is set to turn on the spray to the boom.

To input the boom sections length values, the quick relief switch can be set to turn on or off the spray.

NOTE: To quit the program, move the switch no. 3 downward twice.

PROGRAMMING

4- TEST/SETUP

This function and the following ones are used to program the sprayer model on which the JSC-5000 is installed and to check the operation of the wheel sensor, flowmeter sensor and the spray control motor.

If there is no need to access these functions, move the switch no. 3 downward again (page 15) and the JSC-5000 A will operate normally again.

ACCESSING THE TEST/SETUP FUNCTIONS

- Access the function "Prog./Cal." as described in the page 15.
- Move the switch no. 3 downward 4 times (page 15). The display will show 'TEST/SETUP'.
- Then, move the switch no. 5 downward (page 15). The display will show: "SPRAYER MODEL".
- Again, move the switch no. 5 downward (page 15) that the display will show the sprayer model programmed. To change the sprayer model, move the switch no. 4 downward (page 15).

CHECKING THE WHEEL SENSOR 1

- Move the switch no. 3 downward (page 15).
- The top of the display will show "WHEEL SENSOR 1" and bottom of the display will show the number of cumulative pulses of this sensor when the sprayer moves.

CHECKING THE WHEEL SENSOR 2

- Move the switch no. 3 downward (page 15).
- Proceed as above to check how the WHEEL SENSOR 2 is functioning.

CHECKING THE FLOWMETER

- Move the switch no. 3 downward (page 15). The top of the display will show "FLOWMETER SENSOR" and the bottom of the display will show the number of cumulative pulses of the flowmeter when there is flow through the control.

CHECKING THE ELECTRONIC CIRCUIT THAT ACTUATES THE CONTROL MOTOR

- Move the switch no. 3 downward (page 15) and the display will show "MOTOR".
- If the switch no. 2 (page 15) is set to "MANUAL", the bottom of the display will show "SELECT AUTOMATIC". Proceed as instructed.
- Then the bottom of the display will show "USE SWITCH +/-".
- If you move the switch no. 5 upward (+) (page 15), the control regulator will descend, and the pressure will increase. This way the bottom of the display will show "INC. PRESSURE". Once the regulator rotates all the way, the display will show "HIGH P. LIMIT". If you move the switch no. 5 downward (-), the control regulator will ascend, and the pressure will decrease. This way, the bottom of the display will show "DEC. PRESSURE". Once the regulator rotates all the way, the display will show "LOW P. LIMIT".

PROGRAMMING

CHECKING THE LEVEL SENSOR

- Move the switch no. 3 downward (page 15). The display will show "LEVEL SENSOR". If there is water in the tank, the display will show "WITH WATER", if not, "WITHOUT WATER".

NOTE: After finishing accessing the "TEST/SETUP" functions, move again the switch no. 3 downward once (page 15) and the JSC-5000 A will operate normally again.

MAINTENANCE

The JSC-5000 A is consisted of electric, electronic and mechanical components.

Therefore, to have the JSC-5000 A operate without problems, proceed as follows:

- After the application, put clean water in the tank and run the sprayer to clean inside the circuit.

- When cleaning the machine, do not point the water jet at the controller.

- Make sure the cables are positioned in a way that they will not be compressed or twisted.

- Always keep clean the wheel discs and sensors.

ATTENTION: In order to have always an accurate flow rate reading, periodically clean the flowmeter.

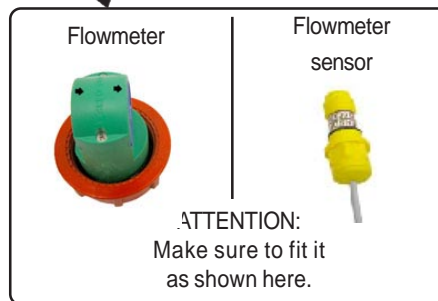
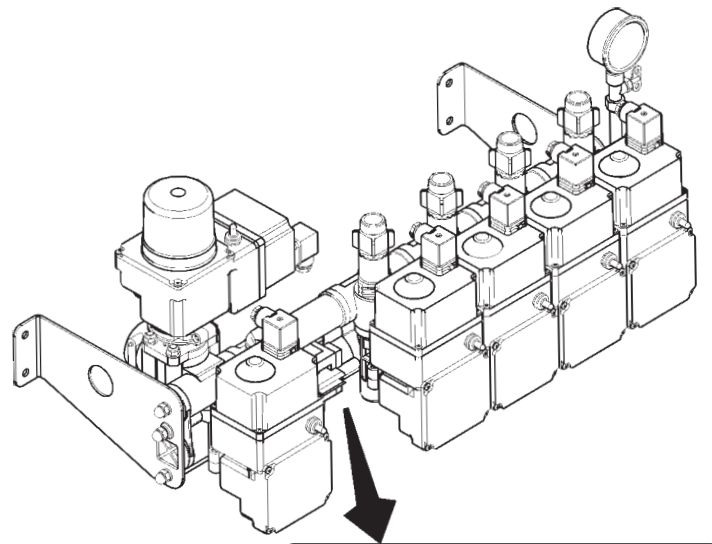

ATTENTION:

In case of highly concentrate wetttable powders or water with suspended particles, you should clean the flowmeter whenever you refill the tank.

When refitting the flowmeter, note that it has different faces and fit as shown above.

MAINTENANCE

MANUAL PRESSURE ADJUSTMENT

In case of any problem on the electronic system, the control can operate mechanically. Then, set the switch no. 2 (page 15) to "MANUAL".

Move the switch A (circled in the figure below) to adjust pressure. This way you can continue to work.

ATTENTION: To operate mechanically, the sprayer should be calibrated in the conventional system, as described in the operator's manual, and the spraying cannot be monitored electronically as well.

If such a problem passes also to the electric system, proceed as follows:

- Set the switch no. 2 (page 15) to "MANUAL".
- Remove the knob cap.
- Remove the pin locking the knob onto the pressure regulator motor.

This way, you can adjust pressure manually.

- For the control to return to operate electronically after the problem is solved, fit the lock pin in the control. First have the arrow on the knob coincide with the arrow on the gear cage cover.

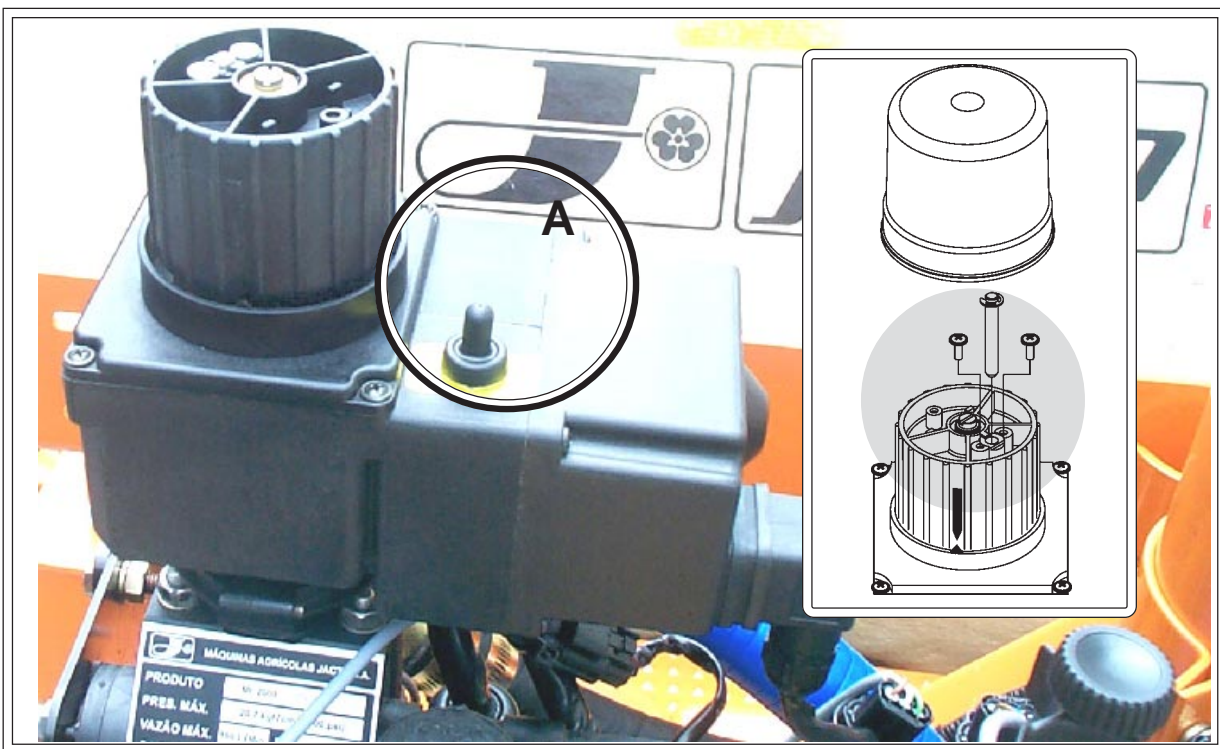

MANUAL OPERATION OF CONTROL LEVERS

- Remove the control electric cable.
- Loosen the two screws and remove the clamps.

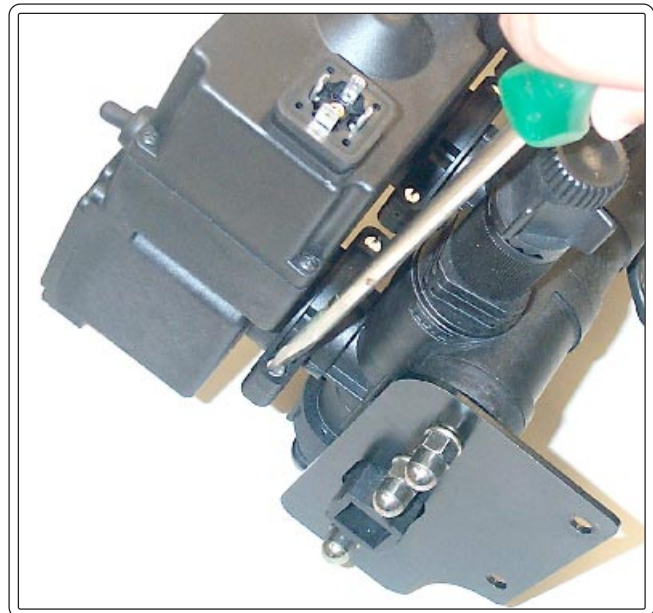
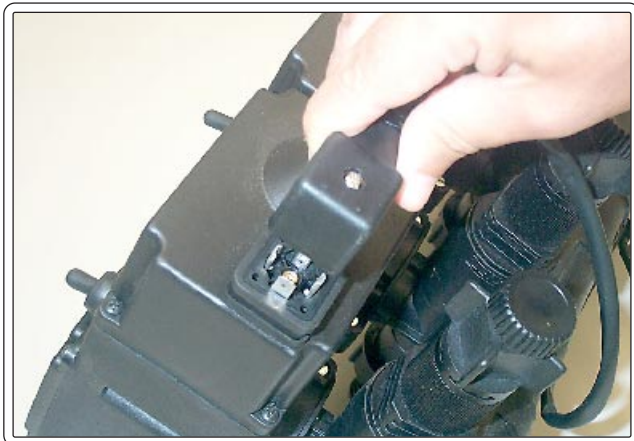

MAINTENANCE

- Remove the electric motor.
- Use an open-end wrench (10 mm - 7/16 inch) to rotate the core for turning on/off the spray.

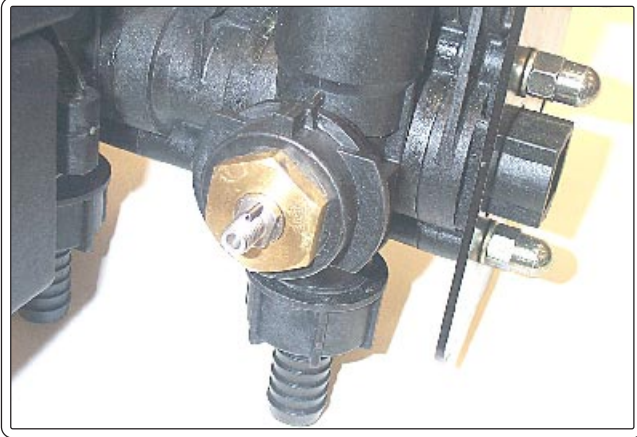

ASSEMBLING THE ELECTRIC MOTOR ON THE CONTROL BODY

- For the perfect assembly of the electric motor on the control body, make sure the hole on the motor block is aligned with the plastic pin on the control core (figure below).
- After assembling the motor block on the control, make sure the clamp is properly positioned to couple the parts. Note the protruding part on one of the clamp sides and position it as shown below.

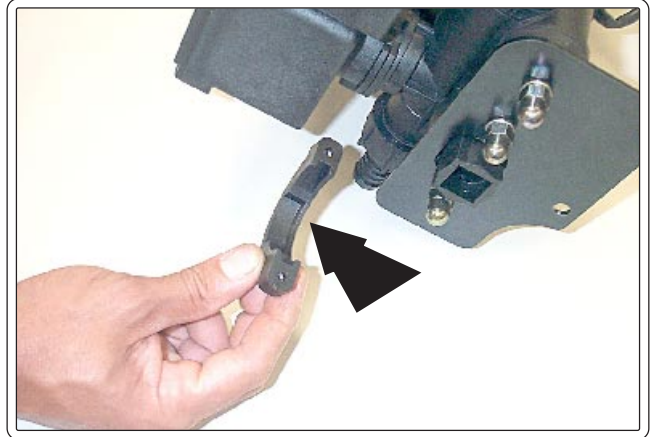
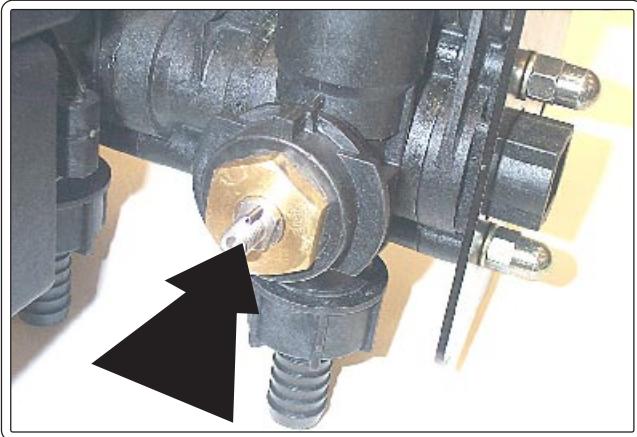

- When connecting the electric cable, note that one of the connectors is different. Make sure the position is correct for perfect fitting.
- Then, fasten the electric cable with the supplied screw.



ATTENTION: Service the control as soon as possible in order to continue to make use of the advantages of the electronic control.

TESTING THE BOOM SECTIONS SENSORS AND SOUND ALARM (SIREN)

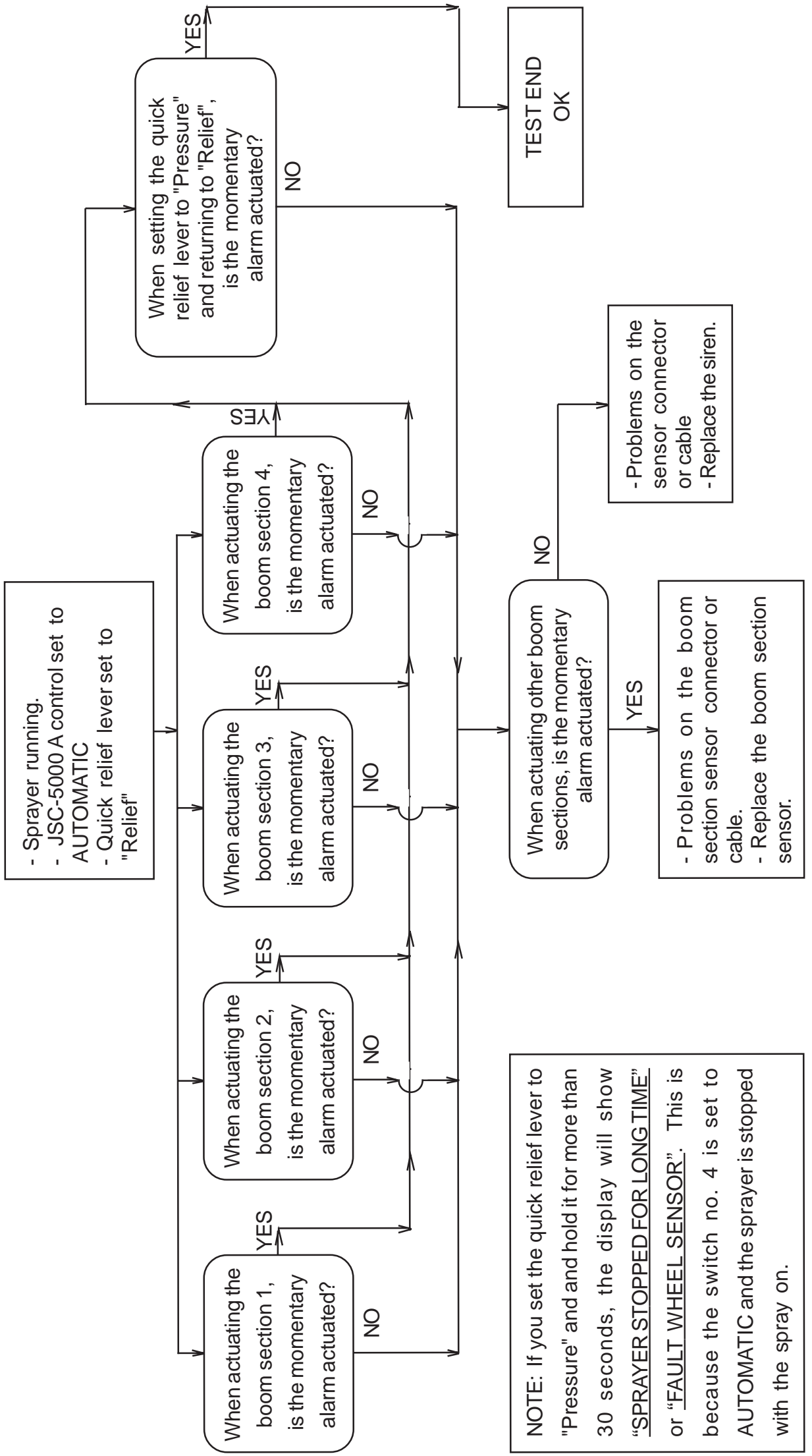

DIAGNOSING ELECTRONIC PROBLEMS

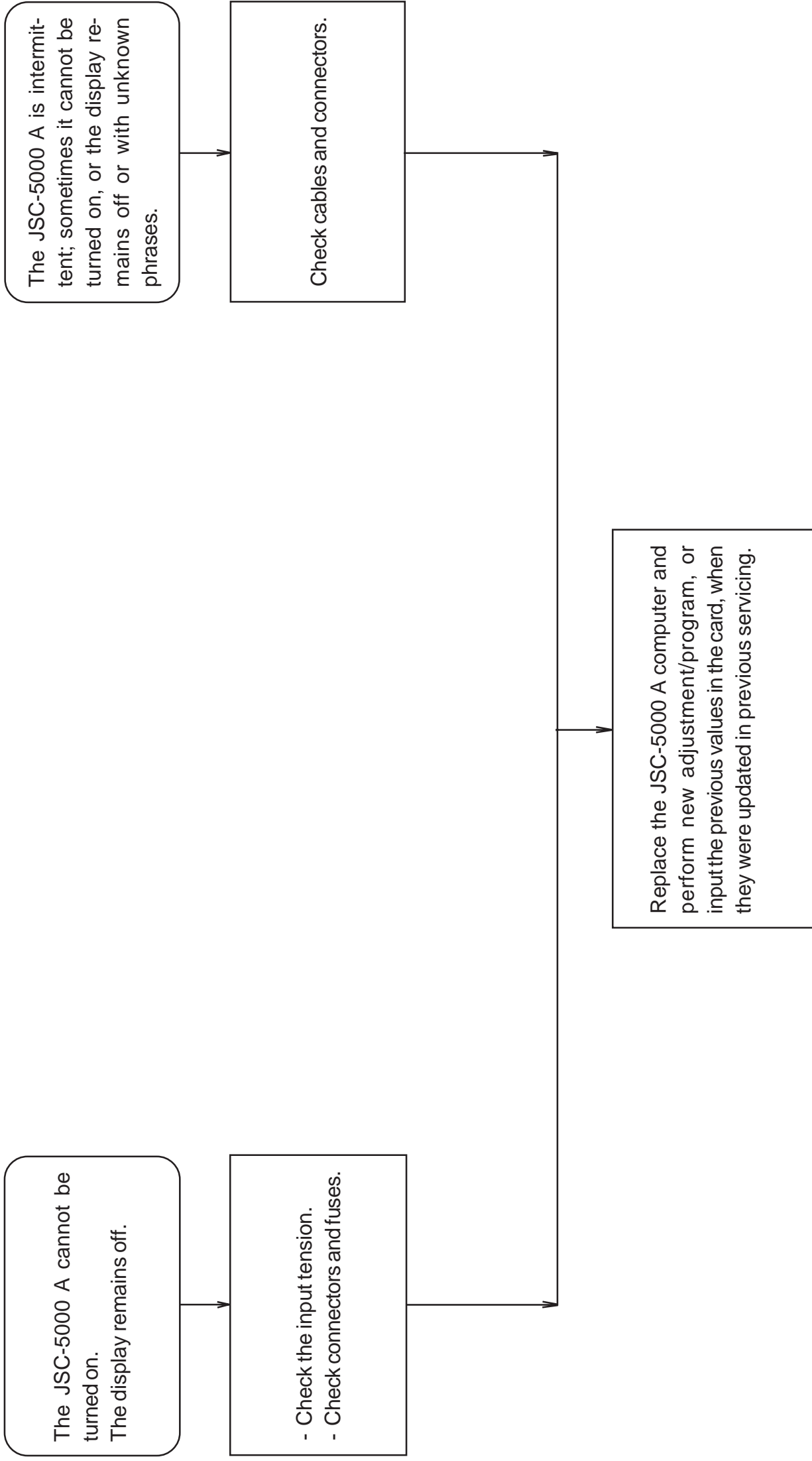

DIAGNOSING ALARMS WHEN PROGRAMMING/ADJUSTING

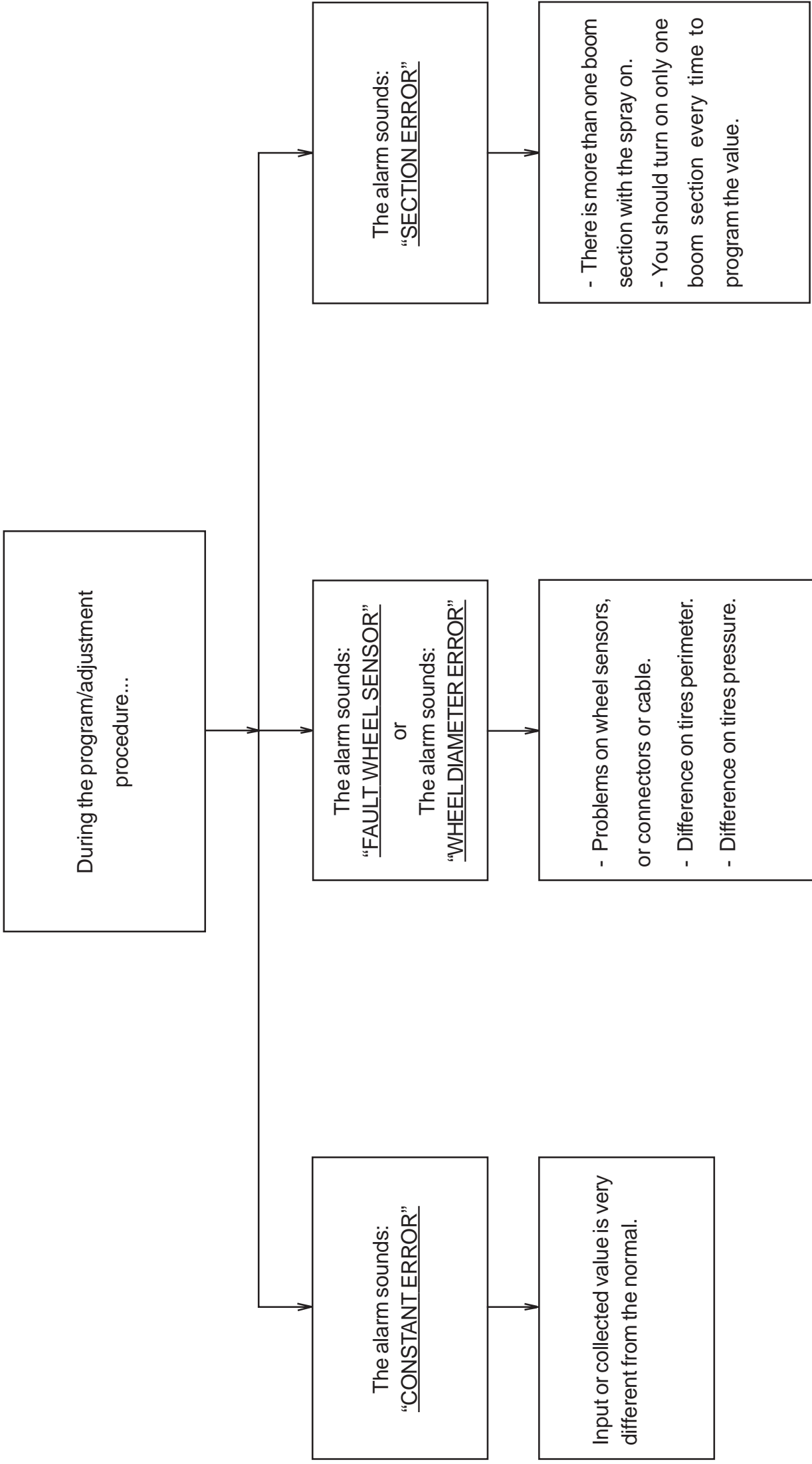

DIAGNOSING DEFECTS ON THE SPRAYERS EQUIPPED WITH THE JSC-5000 A

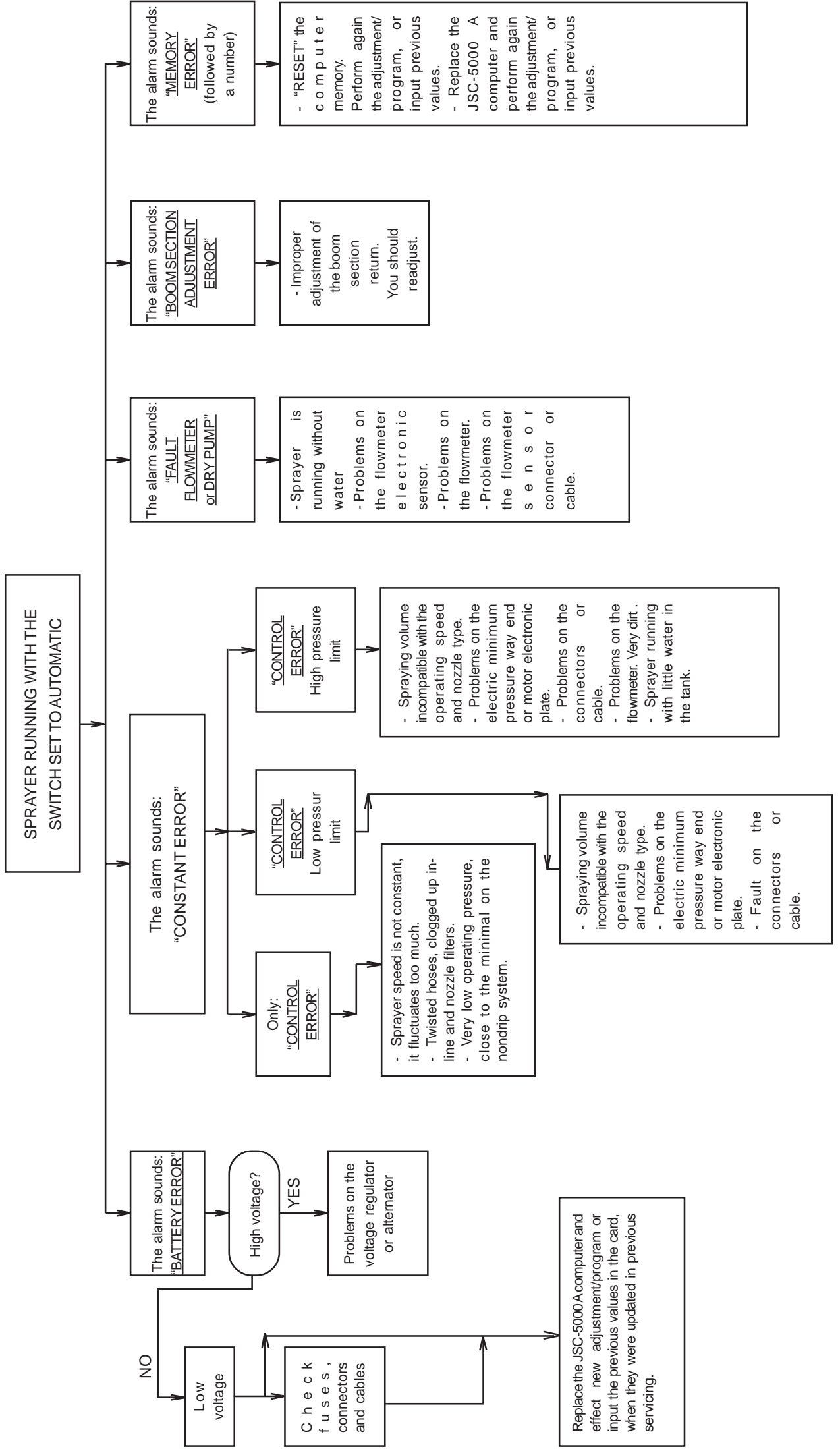

MAINTENANCE

JSC-5000 INSTALLATION DIAGRAM (ADVANCE, CRUZADOR & COLUMBIAAD-18 SPRAYERS)

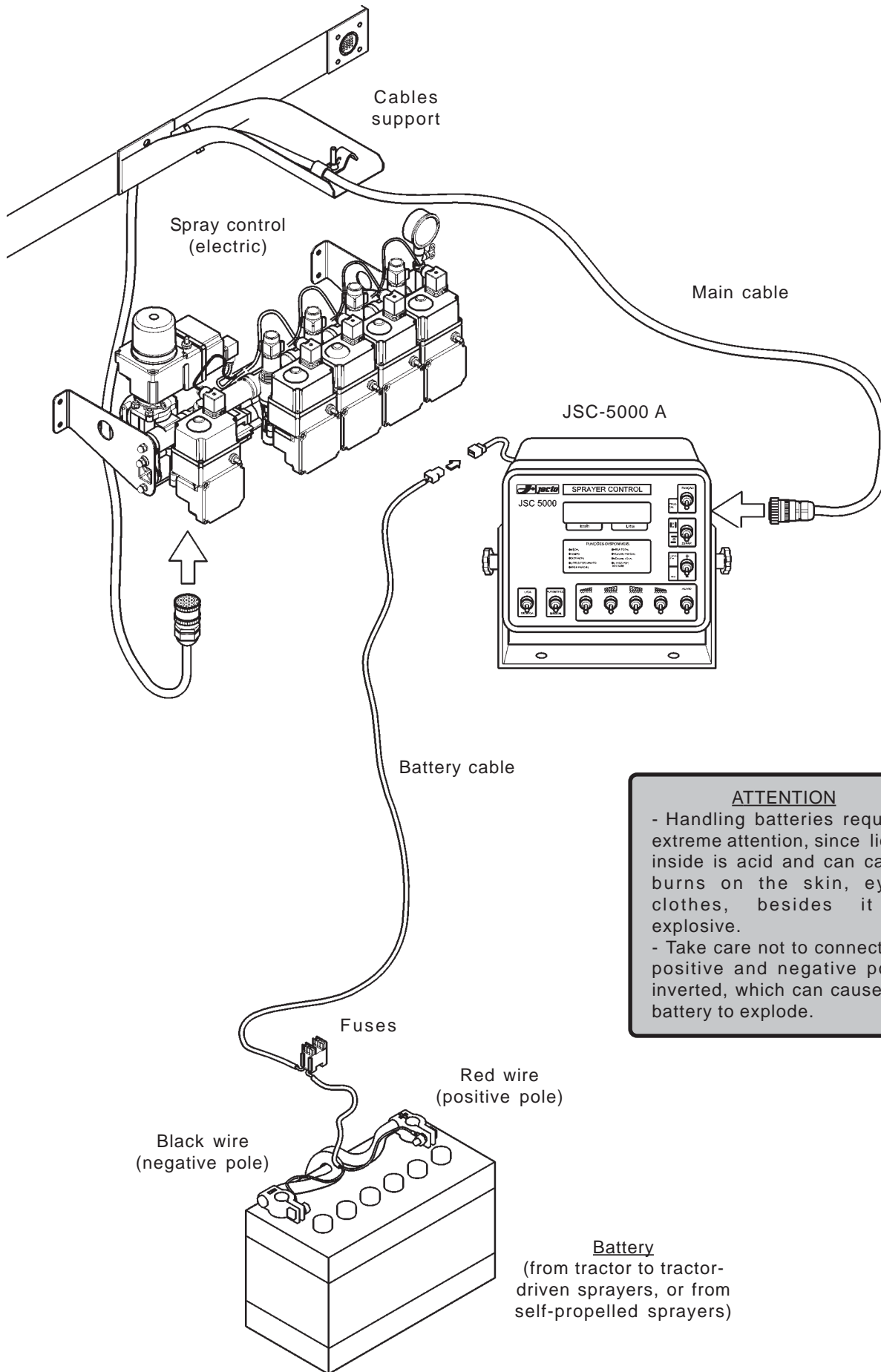

ATTENTION

- Handling batteries requires extreme attention, since liquid inside is acid and can cause burns on the skin, eyes, clothes, besides it is explosive.
- Take care not to connect the positive and negative poles inverted, which can cause the battery to explode.

MAINTENANCE

JEC-3200 / JEC-3400 & ELECTRIC PANEL III INSTALLATION DIAGRAM ON THE ALREADY INSTALLED JSC-5000 A

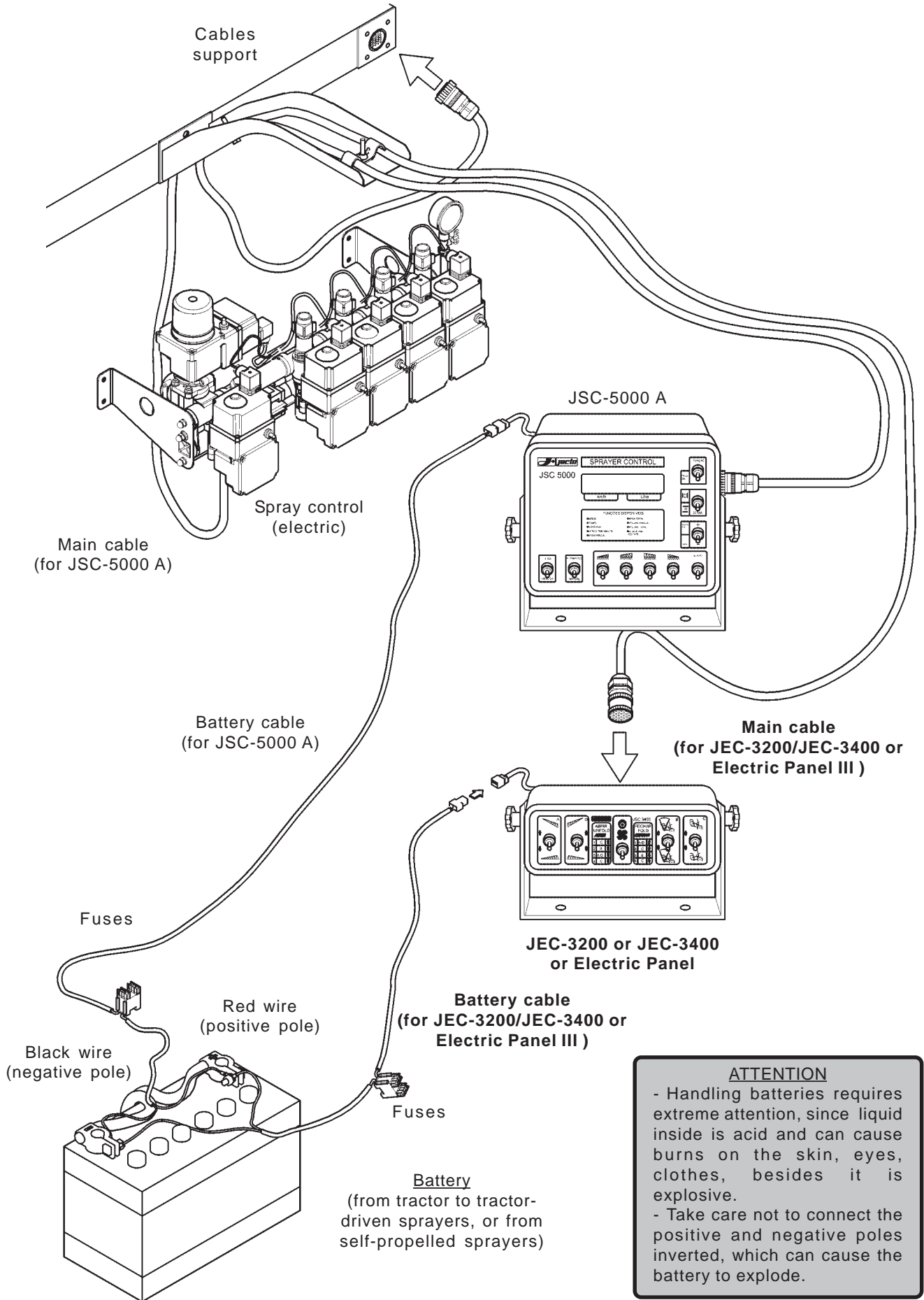

STATEMENT OF LIMITED WARRANTY

MÁQUINAS AGRÍCOLAS JACTO S.A. warrants the equipment described herein and agrees to repair or replace parts and components which, under normal operation and wear, following the technical recommendations, show DEFECTS IN MATERIAL OR WORKMANSHIP.

WARRANTY PERIOD:

- One (1) year from the purchase date by the original retail purchaser.

WARRANTY APPLICATION:

Jacto or its authorized representative shall honor this warranty, if any part or component shows confirmed defect in workmanship.

IT SHALL BE UNDERSTOOD THAT THE REPLACEMENT OF COMPLETE ASSEMBLIES SHALL ONLY BE PERFORMED IN CASE THAT THE DEFECT CANNOT BE REPAIRED BY REPLACING PARTS AND/OR COMPONENTS.

THIS WARRANTY IS NULL AND VOID IF:

- Equipment is not used in accordance with the INSTRUCTION MANUAL, overwork or accidents.
 - Improper preventive maintenance or performed by unauthorized people.
 - Modification of the equipment in any way from the original design.
 - Change, damage, or loss of the product identification plate.
 - Utilization of parts and components not supplied by JACTO.
- PRODUCT REGISTRATION CARD MUST BE COMPLETED BY THE ORIGINAL RETAIL PURCHASER, AND RETURNED TO JACTO DEALER WITHIN 30 DAYS OF PURCHASE DATE.

WARRANTY EXCLUSIONS:

- Parts considered as normal maintenance such as adjustments, retightening, etc.
- Parts which show wear or tear due to use, UNLESS THEY SHOW DEFECTS IN WORKMANSHIP, ASSEMBLY OR MATERIAL.
- Defects resulting from accidents.
- Bodily or property injuries to the user, owner, or third parties.
- Freight charges, pick up and delivery charges.

GENERAL INFORMATION:

- Defective parts replaced under warranty period shall be property of JACTO.
- The warranty of parts and components replaced ends with the expiration of the equipment warranty
- Eventual delays in performing services do not confer the owner the right to indemnity or to extension of the warranty period.
- JACTO reserves the right to change its products or to interrupt manufacturing the equipment.
- THIS LIMITED WARRANTY shall be understood by its expressed terms, and no one in anyway subject to JACTO shall be authorized to modify or amplify the conditions prescribed herein.
- In case of warranty claim, contact the authorized dealer supplying all information required for prompt service. Do not forget the identification of the equipment, total hours of work, and the noticed defect.

FOR THIS WARRANTY TO BECOME EFFECTIVE THE PRODUCT REGISTRATION CARD FOUND IN THE INSTRUCTION MANUAL MUST BE FILLED IN AND RETURNED TO YOUR JACTO DEALER. THIS CARD MUST BE SIGNED BY THE ORIGINAL RETAIL PURCHASER, INDICATING THAT HE HAS READ AND UNDERSTOOD ALL SAFETY AND OPERATIONAL INSTRUCTIONS IN THE MANUAL, FURTHER THE RETAILING DEALER HAS EXPLAINED TO THE ORIGINAL RETAIL PURCHASER ALL SAFETY INSTRUCTIONS. IN NO CASE WILL WARRANTY BE SUPPLIED UNTIL THIS CARD, PROPERLY COMPLETED AND SIGNED, IS ON FILE WITH JACTO RETAILING DEALER.

JACTO RESERVES THE RIGHT TO CHANGE ITS PRODUCTS WITHOUT PRIOR NOTICE.